

Serial Remote Power Switch

User Guide



www.minicom.com

International HQ

Jerusalem, Israel
Tel: + 972 2 535 9666
minicom@minicom.com

North American HQ

Linden, NJ, USA
Tel: + 1 908 486 2100
info.usa@minicom.com

European HQ

Dübendorf, Switzerland
Tel: + 41 44 823 8000
info.europe@minicom.com

Technical support - support@minicom.com

Table of Contents

1.	Welcome	2
2.	Introduction.....	3
3.	SRPS components	3
4.	The SRPS units.....	3
5.	SRPS LEDs.....	4
6.	Rack mounting the SRPS	5
7.	Installing the SRPS	5
8.	Operating the SRPS manually	6
9.	Operating the system via Serial connection	7
10.	Cascading SRPS units.....	11
11.	Cascading more than 1 Slave unit.....	12
12.	Connecting the SRPS to the IP Control	13
13.	Operating the SRPS via IP Control	15
14.	Technical specifications	16

1. Welcome

The Serial Remote Power Switch system is produced by Minicom Advanced Systems Limited.

Technical precautions

This equipment generates radio frequency energy and if not installed in accordance with the manufacturer's instructions, may cause radio frequency interference.

This equipment complies with Part 15, Subpart J of the FCC rules for a Class A computing device. This equipment also complies with the Class A limits for radio noise emission from digital apparatus set out in the Radio Interference Regulation of the Canadian Department of Communications. These above rules are designed to provide reasonable protection against such interference when operating the equipment in a commercial environment. If operation of this equipment in a residential area causes radio frequency interference, the user, and not Minicom Advanced Systems Limited, will be responsible.

Changes or modifications made to this equipment not expressly approved by Minicom Advanced Systems Limited could void the user's authority to operate the equipment.

Minicom Advanced Systems Limited assumes no responsibility for any errors that appear in this document. Information in this document is subject to change without notice.

No part of this document may be reproduced or transmitted in any form or by any means, electronic or mechanical, for any purpose, without the express written permission of Minicom Advanced Systems Limited.

Trademarks

All trademarks and registered trademarks are the property of their respective owners.

2. Introduction

The Serial Remote Power Switch (SRPS) is a Serial ready device that remotely controls the AC power of up to 8 connected devices. You can cascade up to 15 Slave units to control a total of 128 devices via a Serial connection.

A user can power on/off, reboot or safe shutdown any server or hardware device that is physically connected to the SRPS.

3. SRPS components

The SRPS system has the following components:

- SRPS Manager - 115VAC or 230VAC model
- Rack-mount brackets
- 2 AC Power cords
- 1 Serial cable (RS232 - RS232 connectors)
- 8 Serial cables (RJ-11 - RS232 connectors). To perform safe shutdown.
- 1 iLink cable. For SRPS cascading or UPS connection
- 2 Terminators
- Linux safe shutdown utility located on the Marketing & Documentation CD

You can cascade the system by adding up to 16 SRPS Slave units.

4. The SRPS units

The figures below illustrate the SRPS Manager and Slave front and rear panels. The Slave is the same as SRPS Manager without the Serial card.

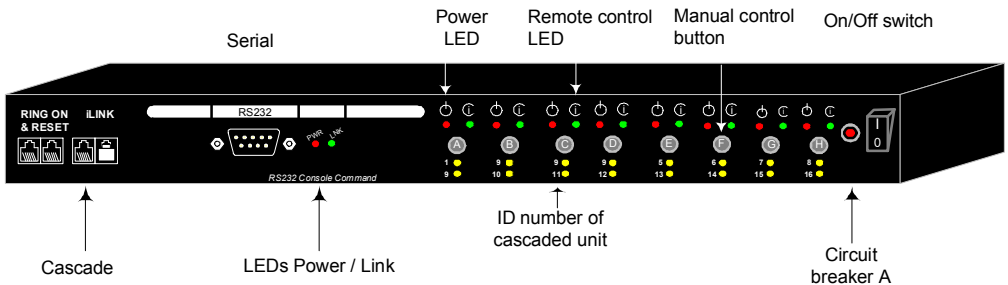

Figure 1 SRPS Manager front panel

SERIAL REMOTE POWER SWITCH

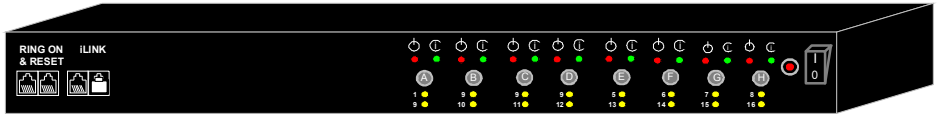

Figure 2 SRPS Slave front

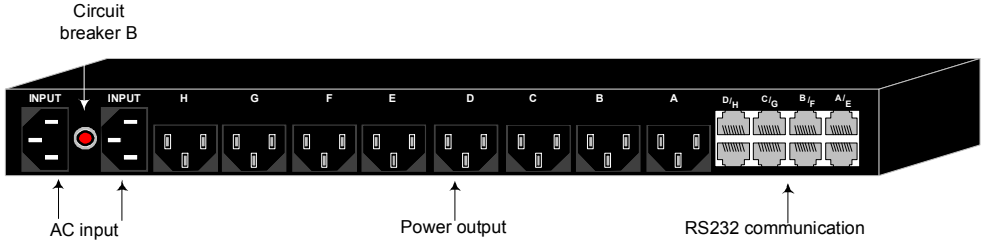

Figure 3 SRPS Manager and Slave rear panel

Note: The letter on the manual buttons at the front corresponds to the outlet with the same letter at the rear.

5. SRPS LEDs

Figure 4 illustrates the LEDs on the SRPS Manager and Slave units.

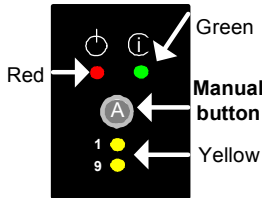

Figure 4 SRPS LEDs + manual button

LED	On	Off	Flashing
Red Power	The outlet is powered on	The outlet is powered off	The outlet has an internal fault.
Green Remote control	The outlet is controlled Serially	The outlet is controlled manually	To change from Serial to manual control. Press and hold the manual button for 3 seconds. During these 3 seconds the LED flashes
Yellow ID number	Indicates the SRPS ID number. The master displays all the connected SRPS ID numbers. The slave displays its own ID number		

6. Rack mounting the SRPS

The SRPS comes with brackets for mounting onto a standard 19-inch rack.

To rack mount the SRPS:

1. Choose a location for the brackets. A notched hole on the vertical rail denotes the middle of a U slot.
2. Connect the mounting brackets to the unit, using the screws provided. See Figure 5.

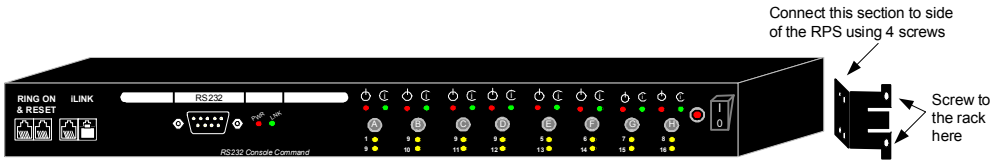

Figure 5 Connecting the mounting brackets

7. Installing the SRPS

1. Connect the power cord sockets of the computers and other devices to the Output ports of the SRPS, see Figure 6.

Important! For operational purposes the computer connected to Output port A is device #1. The computer connected to Output port B is device #2, etc. So connect the computers logically. I.e. connect the computer connected to the KVM switch port #1 to the SRPS Output port #1. etc.

2. Connect the SRPS to the power supply using the 2 power cords, or connect the socket of any Uninterruptible Power Supply (UPS) to the Input ports of the SRPS.
3. Connect the Serial cable (RS232 - RS232 connectors) to the Serial port of the SRPS and a Serial Terminal or to a computer's Serial port.
4. Plug a Terminator into one of the iLINK ports.

Connection diagram

The figure below illustrates the basic SRPS connections.

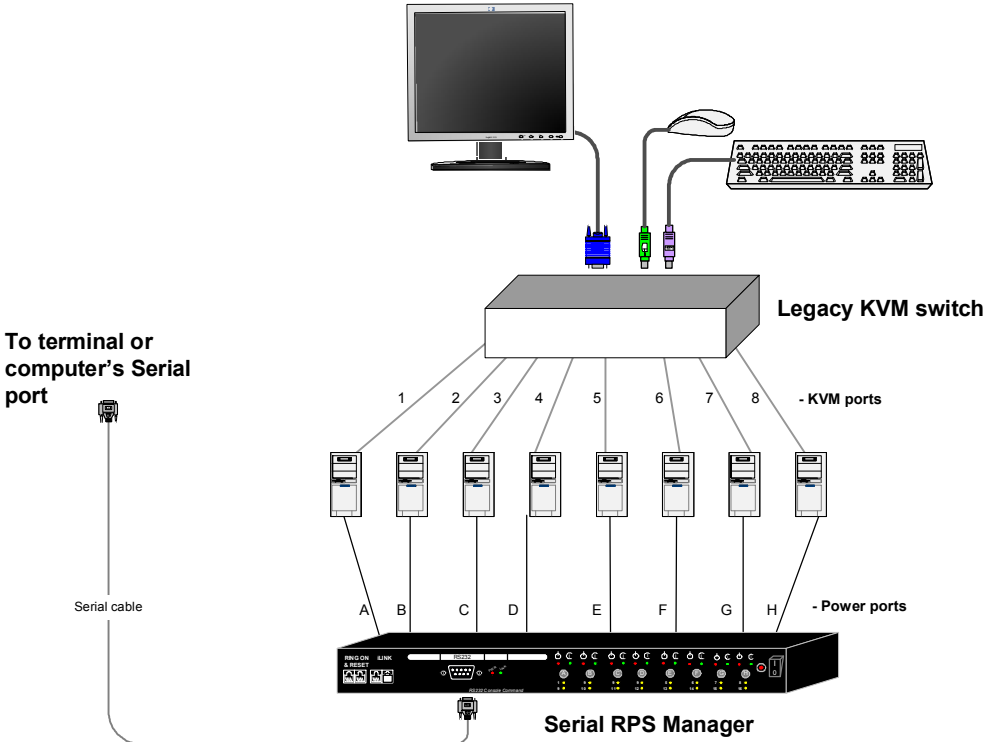

Figure 6 SRPS connection diagram

8. Operating the SRPS manually

You can operate the SRPS manually using the manual buttons on the front panel. See Figure 4.

When a power outlet is in manual mode, you cannot operate it via the Serial connection. When the green LED is off, the outlet is in manual mode. When it is on, the outlet is in Serial mode. To change from manual mode to Serial mode and vice versa, press and hold the manual button for 3 seconds. The green LED flashes and the mode is changed.

In manual mode, press the manual button to switch the outlet on or off. The red LED on indicates the socket is powered on. The red LED off indicates the socket is powered off.

9. Operating the system via Serial connection

5. Use a Serial terminal or a Serial emulation program via a computer to connect to the SRPS Manager. The screen shots below use Windows Hyperterminal.
6. Choose Start/Programs/Accessories/Communications/Hyperterminal.
7. When prompted enter a name and click OK. The Connect To box appears. See Figure 7.



Figure 7 Connect To box

8. Fill in the connection details. In the Connect using box select the COM port the Serial cable is connected to and click OK. The COM properties box appears. See Figure 8.

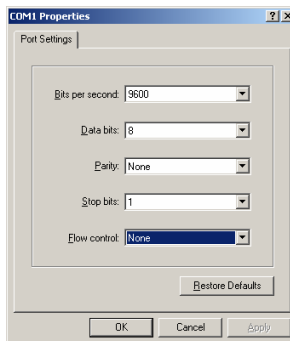

Figure 8 COM 1 Properties box

9. Set the port settings to the following values:
 - Bits/second - 9600
 - Data bits - 8
 - Parity - None
 - Stop bits - 1
 - Flow Control - None

10. Click OK. The Hyperterminal appears. See Figure 9.

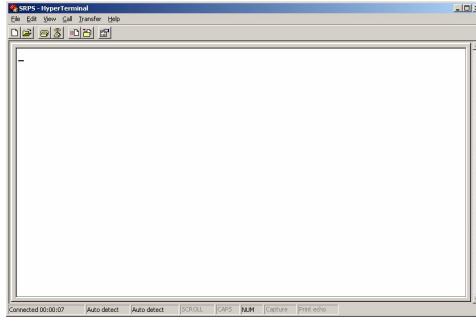

Figure 9 Hyperterminal

11. Click File/Properties, Settings tab. Figure 10 appears.

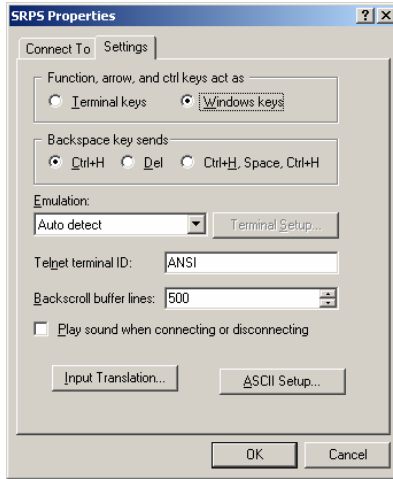

Figure 10 Settings tab

12. Ensure the values are as set out in Figure 10. Check **Windows keys** and select **Auto detect** for Emulation.

13. Click the ASCII setup button. Figure 11 appears.

14. Ensure the values are as set out in Figure 11. Check the 2 top fields, and change **Character delay** to 1.

15. Click OK.

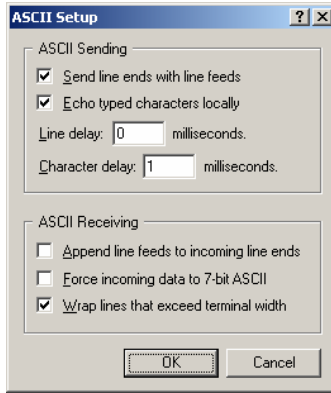

Figure 11 ASCII setup

16. Open any text editor to type commands into.

IMPORTANT!

Type the commands as set out in the table below into the text editor. Copy and paste them into the Hyperterminal by right-clicking inside the Hyperterminal, a menu appears, click Paste to Host.

Description	Command	Comment
Echo Device Address	^isP003EAD	^iSWITCH01,^iSWITCH02,...
Echo Homepage	^isPxxx(len)HMEfilename	^iDXXXX..., XXXXX is len
Address Start	^isS005ADRxx	^isS005ADRxx, Address xx start
Address End	^isS003END	
Outlet on	^isS004ONSn	^isS004ONS1-8, outlet 1-8on
Outlet off	^isS004OFSn	^isS004OFS1-8 outlet 1-8off
Echo Status	^isP003STS	^iDXXXnn(Address),nn, outlet status (S1,S2,S3,S4,S5,S6,S7,S8), nn is outlet number, S1-8, 0 off, 1 on, 2 pending, 3 fault
Configure Address	^isS005CFGxx	^isS005CFGxx, configure current address to address xx
Set outlet Identification	^isSxxx(len)UIDn,Identification	^isSxxx(len)UIDn, Identification, set outlet(0-8) Identification, 0 is SRP Manager identification
Get outlet Identification	^isP003UID	^iDxxx(len)0iden,1iden,2iden,3iden,4iden,5iden,6iden,7iden,8iden
xx(1-7 Date), n(outlet 1-8), D(1,0) 1 is enable, 0 is disable, X(1,0) 1 is on timer, 0 is off timer, HH is hour, MM is minutes	^isSxxx(len)SCHxx,n,D,X,HHMM M,xx,n,D,X,HHMM	^isS016SCH01,1,1,1,1,1200
xx(1-7 Date), n(1-8 sw)	^isP007SCHxx,n	^iDxxx(len)D,1,HHMM,D,0,HHMM, D 1 is enable, 0 is disable, 1HHMM is time on, 0HHMM is time off

SERIAL REMOTE POWER SWITCH

Description	Command	Comment
Set real time	^isS020TMEyyyy,mm,dd,n,HH MM	yyyy is year mm is month dd is date n is Monday to Sunday (1-7) HH is hours MM is minutes
Set Safe shutdown enable/disable, X 1 is enable, o is disable	^isS018SUDX,X,X,X,X,X,X,X	Outlet (1-8)
Get safe shutdown setting status	^isP003SUD	^iD015X,X,X,X,X,X,X,X(outlet 1-8)
Set Power Return SW on delay time, n is 1-8, SSSS is seconds. Max 65535 sec.	^isSxxx(len)DLYn,SSSS	^isS006DLY1,4
Set Client Device No XX is Client	^isS005DNOxx	xx is Client Device No
Device(Binary)	^isS005DEVXX	XX is two byte binary value, bit 15-bit0 indicates ID16 to ID1
Set power return delay time, n is 1-8	^isP004DLYn	^iD00500004, time is in seconds
Set telephone interface	^isS003TEL	
Set reboot enable/disable	^isS018RBTX,X,X,X.X.X.X.X	
Get reboot setting status	^isP003RBT	
Set all outlets on/off command, X 1 is all on, 0 is all off	^isS004ALLX	
Set shutdown time, n is outlet(1-8), SSSS is Seconds max 9999 sec.	^isSxxx(len)DLTn,SSSS	^isS006DLT1,4
Get shutdown time, n is outlet(1-8)	^isP004DLTn	^iD00500004, time is in seconds
Set output group status. N is (0-8) 0 is total outlets,(1-8) indicate A-H outlets	^isP004ST1n (for future implementation, maybe support)	^iDxxxFFF,VVVV,IIII,WWWWW,PPP xxx is length, FFF is output frequency (unit .1Hz), VVVV is output voltage (unit .1V), WWWWW is output power in watts, PPP is percent of power capacity

Some examples

To	Type
Power off SRPS 1 Outlet D	^isS005ADR01^isS004OFS4
Power on SRPS 2 Outlet B	^isS005ADR02^isS004ONS2
Get the Safe Shutdown Status of SRPS 1	^isS005ADR01^isP003SUD
Set Safe Shutdown of SRPS 1: ON at outlet B,D,H and OFF at A,C,E,F,G	^isS005ADR01^isS018SUD0,1,0,1,0,0,0,1
Get shutdown time of SRPS 3 Outlet E	^isS005ADR03^isP004DLT5

10. Cascading SRPS units

You can cascade up to 16 SRPS units (1 Manager + 15 Slaves). Each SRPS must have its own unique ID number and the ID numbers must also be in a logical sequence. The default ID number of the Manager SRPS is 1. The default ID number of all Slave SRPS units is 16. So to be in a logical sequence where there is 1 Slave, change the Slave ID number to 2. For each additional Slave give it the next number - ID no 3, then 4 etc.

Changing 1 Slave's ID number

1. Power off the SRPS Manager and Slave unit.
2. Connect the SRPS Manager to a computer using the Serial cable.
3. Plug a Terminator into one of the SRPS Manager's iLINK ports and one into one of the Slave's iLINK ports. See Figure 12.



Figure 12 Connecting the iLink cable

4. Connect the iLink cable to the iLINK ports of the SRPS Manager and Slave unit. See Figure 12.
5. Power on the SRPS Manager and the Slave.
6. Type the instructions as set out below using a Terminal or terminal emulation software. See page 7 Operating the system to set up a HyperTerminal. Confirm the current ID nos. by pasting `^isP003EAD`. HyperTerminal responds with `^iSWITCH01`, `^iSWITCH16`.

SERIAL REMOTE POWER SWITCH

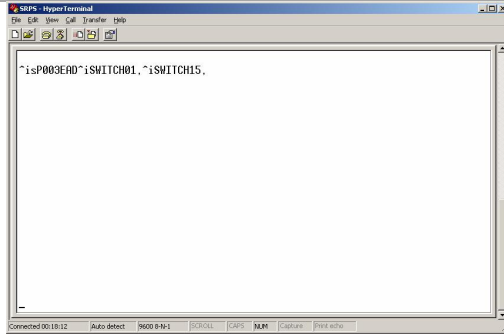

Figure 13 Hyperterminal response

7. Change the SRPS Slave's ID number to 2 by pasting:

```
^isS005ADR16^isS005CFG02 .
```

8. Paste **^isP003EAD**. HyperTerminal responds with **^iSWITCH01, ^iSWITCH02**.

11. Cascading more than 1 Slave unit

When cascading more than 1 Slave, connect the Slaves one at a time in the procedure outlined above, and change the Slave ID number. Once the ID number is changed, connect the next Slave and change that Slaves ID Number (You do not need to disconnect the first Slave once it has a new ID number).

Connect the Terminators and iLINK cables as follows:

1. Plug a Terminator into the Manager iLINK port and the iLINK port of last Slave to be cascaded. See Figure 14.

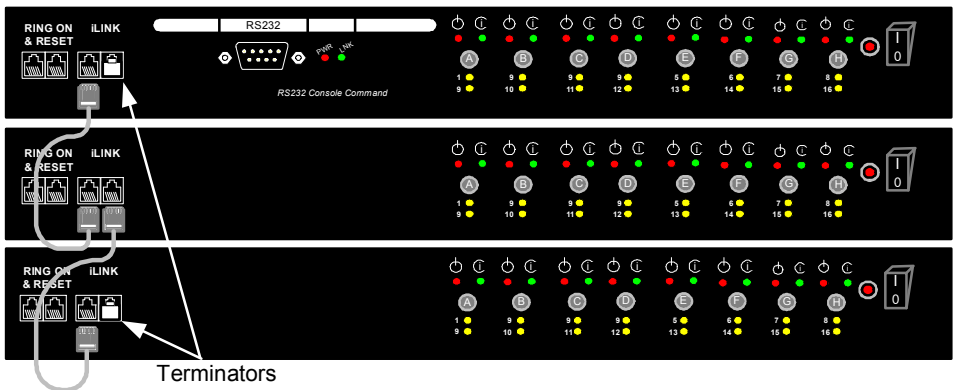

Figure 14 Adding more Slaves

2. Connect an iLINK cable to the iLINK ports of the SRPS Manager and a Slave unit. See Figure 14.

3. Connect further iLink cables to the iLINK ports of the rest of the Slaves.
4. Connect the Power cord of each server to the Output ports of SRPS units.
5. Operate the system as set out on page 7.

12. Connecting the SRPS to the IP Control

You can connect the SRPS to the IP Control and then manage the power of the servers seamlessly via they IP Control remote GUI.

6. Connect the Serial cable (RS232-RJ45 connectors - this cable is supplied with the IP Control) to the Serial port of the SRPS and the IP Control– see Figure 15.
7. Connect the IP Control to the KVM switch using the KVM cable.
8. Connect the SRPS to the power supply using the power cord, or connect the socket of any Uninterruptible Power Supply (UPS) to the Input ports of the SRPS.
9. Plug a Terminator into one of the iLINK ports.
1. Connect the Power cord of each server to the Output ports of SRPS units according to their logical number. In Figure 15 the server connected to KVM port 1 must be connected to SRPS Output port A. The server connected to KVM port 2 must be connected to SRPS Output port B etc

Cascading example. You cascade a 16 port KVM switch to 2 SRPS units. The SRPS Manager is ID number 1 and the Slave is ID number 2. So servers 1 – 8, i.e. the servers connected to the KVM switch ports 1 – 8 must be connected as follows: Connect server # 1 to SRPS ID number 1, socket A and server # 2 to SRPS ID number 1, socket B etc. The servers connected to the KVM switch ports 9 – 16 must be connected as follows: Server # 9 to SRPS ID number 2, socket A, server # 10 to SRPS ID number 2, socket B, etc. See Figure 16.

SERIAL REMOTE POWER SWITCH

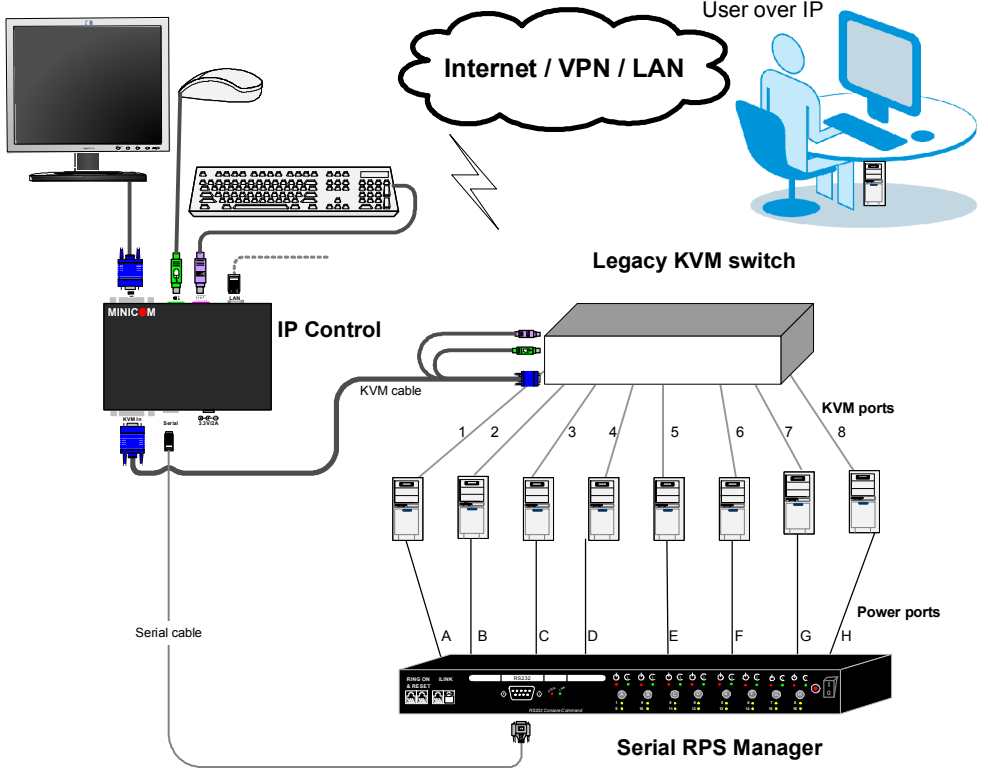

Figure 15 SRPS and IP Control connections

To IP Control

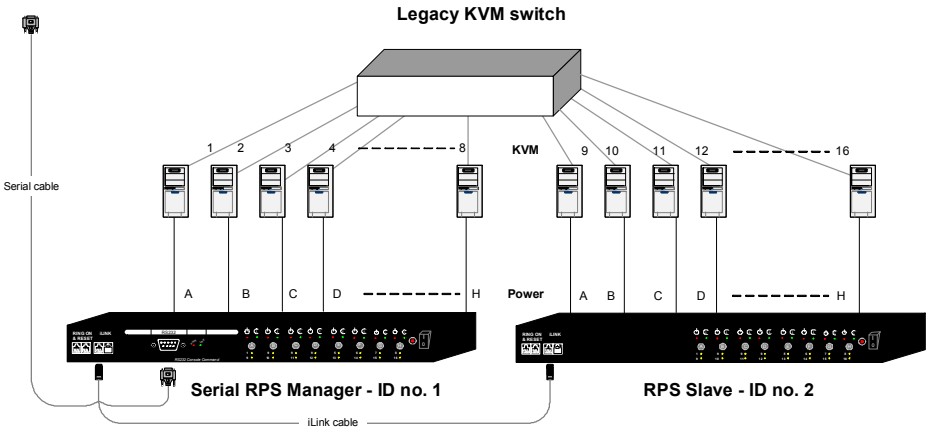

Figure 16 Cascaded SRPS units

13. Operating the SRPS via IP Control

1. Configure the IP Control to work with the SRPS. From the IP Control Administration menu click Serial Settings the **Serial Settings** appear, see Figure 17. See the IP Control User Guide for more details.

Administration > Serial Settings

Serial Port

Device Name: CharSet:



Baud Rate: Data Bits:

Parity: Stop Bits:

Show: Assign to RPS:

Figure 17 Serial Settings

2. Check the Assign to SRPS box and save. The system is ready to work.

3. From the Toolbar, click , or right-click . A list of connected servers/devices appears.

4. Click the desired server or Serial device. The screen of the server or the Serial device window appears.

5. From the Toolbar, click . The Power menu appears, see below.

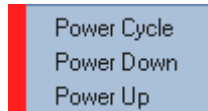

Figure 18 Power menu

6. To send a power cycle command or to power down or up the currently accessed Target server, select the appropriate option.

Note! Only the currently accessed Target server is affected, so to power manage other Target servers you must access each one individually.

See the IP Control User Guide for more details.

14. Technical specifications

	Remote Power Switch Manager	Remote Power Switch Slave
Reset button	Yes	N/A
iLink interface	2 x RJ11, connection to cascaded unit	
NT safe shutdown	8 x RJ11	
Power control	2 AC inputs each feeding 4 outputs	
Input	2 input connectors IEC320P	
Output	8 x IEC320R	
Power protection	7 Amp circuit breaker	
LEDs - Red	On/Off status 1 LED for each outlet	
LEDs - Green	Indicates internet/non internet control 1 LED for each outlet	
LEDs - Yellow	Indicates the ID number of iLink cascade - 16 LEDs	
Nominal input voltage	220V model and 110V model	
Frequency	50/60HZ full range	
Maximum output capacity	110V model: 2 x 15Amp 220V model: 2 x 7Amp	
Operating temperature	0°C to 40°C/32°F to 104°F	
Storage temperature	-40°C to 40°C/-40°F to 104°F	
Relative humidity	0 - 95% non - Amp circuit breaker	
Dimensions (H x L x D)	4.4 x 43.1 x 16.2 cm / 1.73 x 16.96 x 6.37 ft	
Weight	2.5 kg / 5.51 lb	
Regulatory compliance	UL, FCC	

User Guide Feedback

Your feedback is very important to help us improve our documentation. Please email any comments to: ug.comments@minicom.com

Please include the following information: Guide name, part number and version number (as appears on the front cover).

Regional Offices

Germany

Kiel

Tel: + 49 431 668 7933

info.germany@minicom.com

France

Vincennes

Tel: + 33 1 49 57 00 00

info.france@minicom.com

Italy

Rome

Tel: + 39 06 8209 7902

info.italy@minicom.com

England

Camberley

Tel: + 44 (0) 1276 25053

info.uk@minicom.com

www.minicom.com

