

SmartRack 232 - Quick Start Guide



1. Introduction

To take advantage of the full range of features, we recommend you read the softcopy User Guide after performing the Quick Start procedure. It's in PDF format on the supplied CD or on our website www.minicom.com in the Support section.

2 users can access and control multiple mixed-platform computers with the SmartRack 232 Switch system. Connect up to 32 computers to the SmartRack 232.

The SmartRack 232 is based on Minicom's innovative ROC technology in which each computer / server is directly connected to the switch via a ROC using standard CAT5 cable at a distance of up to 30m/100ft in a star configuration. No external power is needed at the ROCs.

To access servers, just slide out the drawer and flip up its top to display the large, high resolution 17" TFT LCD display.

The display is (VGA/SVGA/XGA/SXGA compatible) with front-panel high-quality controls and touchpad for easy adjustment.

1.1 Compatibility

The SmartRack 232 is compatible with:

- PS/2, and USB computers/servers
- DOS, Windows, Linux, UNIX, Mac and all other major operating systems

2. System components

The SmartRack 232 system consists of:

- SmartRack 232: Console + KVM Switch
- ROCs - PS/2, USB (ordered separately. ROC comes with CAT5 cable 1.5m)

3. Hardware kit contents

Rail with front and rear bracket x 2,
for rack depth of 614 ~ 800 mm.

Right and left sides are different.

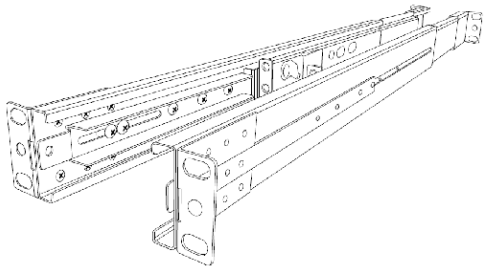

Long bracket x 2. (For increased rack depth of 905 ~ 990mm)

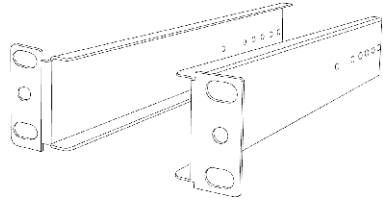

Medium bracket x 2. (For increased rack depth of 800 ~ 905mm)

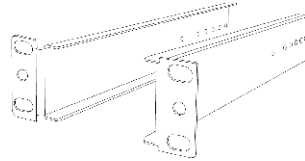

Short bracket x 2

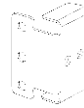

Bracket attachment x 2



Note! The short bracket and bracket attachment for a rack depth of 504~ 614 mm and without a KVM switch connected to the drawer.

Flat screws x 6 (for rail mount to console body) 

Screws x 6 

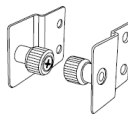

Bracket A with thumbscrew x 2

Screws x4 

Keys x 2. 

4. Pre-installation guidelines

- Switch off all computers
- Place cables away from fluorescent lights, air conditioners, and machines that are likely to generate electrical noise

- Ensure that the maximum distance between each computer and the SmartRack 232 does not exceed 30m/100ft

5. Connecting to a rack

Note! For increased rack depth of 800 ~ 990mm, first change the bracket to the medium or long bracket, see section 5.1 on page 5.

Note! The illustrations below show the connections to one side of the SmartRack 232. The connections are the same for the other side.

1. Move the rail until two screws appear, see Figure 1.

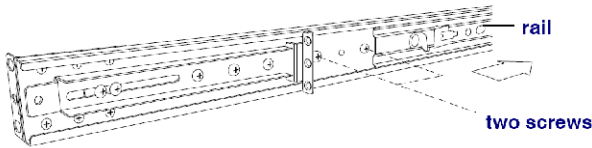

Figure 1 Exposing the 2 screws

2. Loosen slightly the 7 screws as shown below.

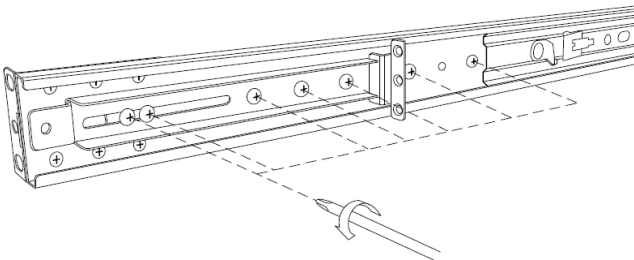

Figure 2 Loosen 7 screws

3. Adjust the rear bracket to fit your cabinet, see below.

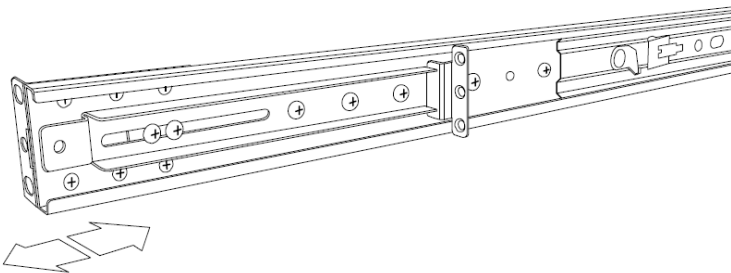

Figure 3 Adjusting the bracket

4. Install the front and rear bracket onto the cabinet, see figure below.

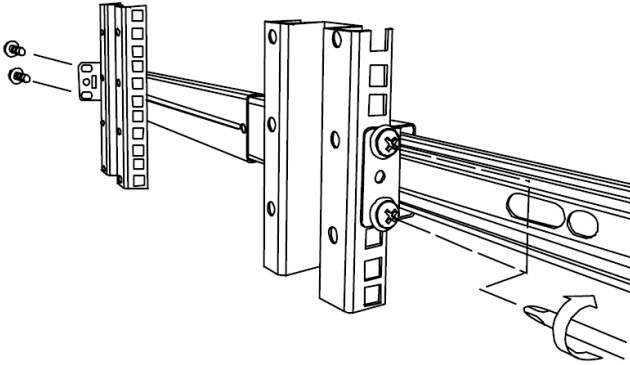

Figure 4 Installing front and rear bracket on cabinet

5. Tighten the 7 screws as shown below.

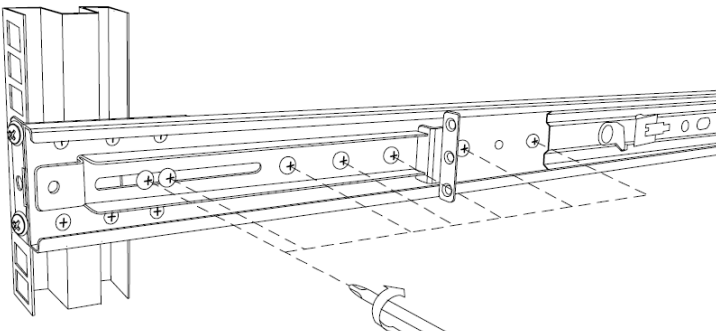

Figure 5 Tightening the 7 screws

6. Repeat the steps above to connect the other rail to the other side of the rack.
7. Slide the SmartRack console between the rails as shown below.

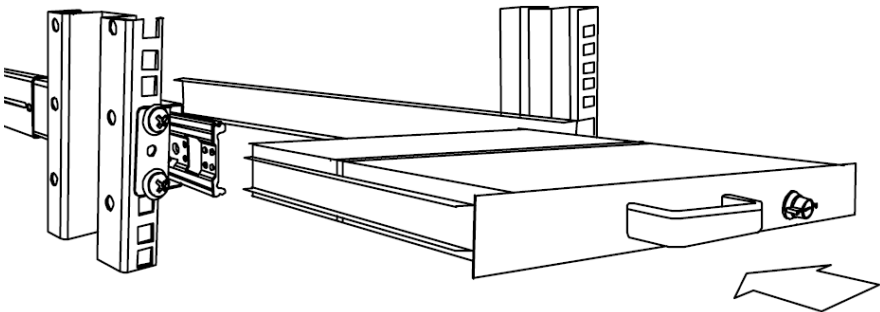

Figure 6 Sliding the SmartRack between the rails

8. Unlock and pull both left and right rail-lock switches together – see below – and push the console all the way into the rack.

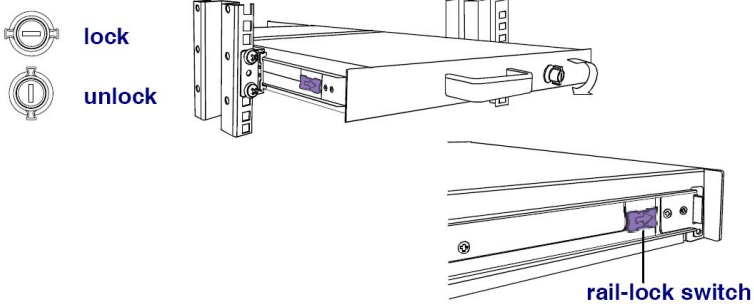

Figure 7 Rail-lock switch

9. Connect three flat screws to the rear of the console on both sides. See figure below.

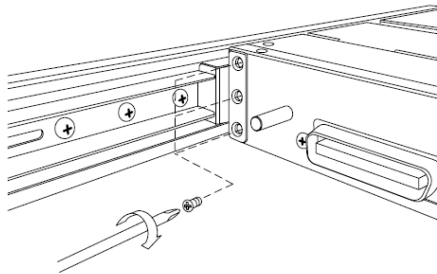

Figure 8 Connecting three flat screws to the rear of the console

The console now sits snugly in the rack, see Figure 9.

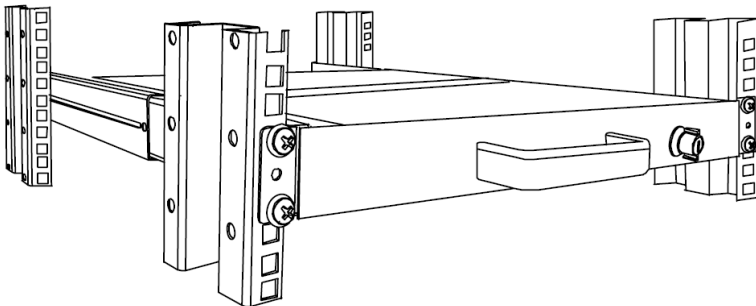

Figure 9 Console in the rack

5.1 Using the medium or longer bracket

For a rack depth of 800 ~ 905mm, use the medium bracket. For a rack depth of 905 ~ 990mm, use the longer bracket.

To replace the bracket with the medium or longer bracket:

1. Loosen the 7 screws as shown below.

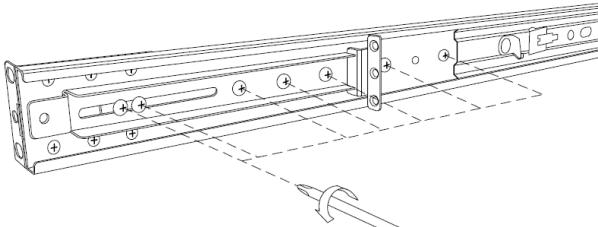

Figure 10 Loosening the 7 screws

- Remove the six (different) screws as shown below.

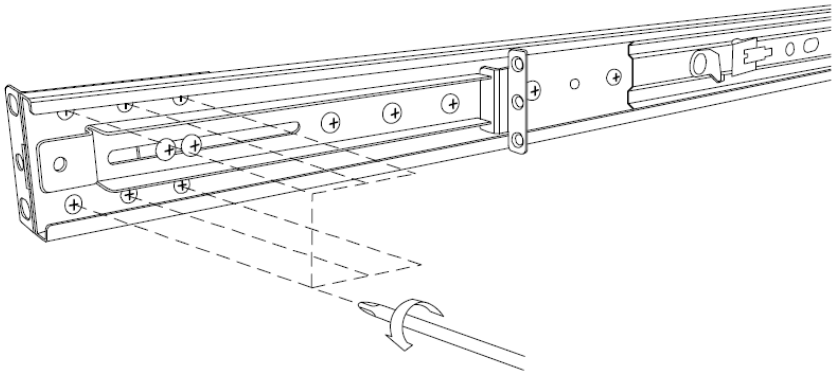
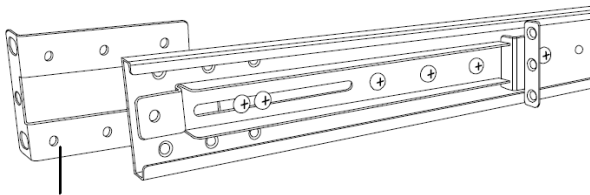



Figure 11 Removing the six screws

2. Take the rear bracket out, see below.



original bracket

Figure 12 Taking the rear bracket out

3. Insert the medium/long bracket into the rail then adjust the bracket to fit your cabinet.
4. Tighten at least 2~3 screws along the length you need. **Note!** For medium bracket use the round screws , and for the long bracket use the flat screws . See Figure 13.

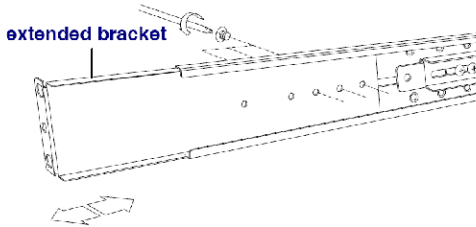

Figure 13 Inserting and tightening the long bracket

5. Repeat the above steps for the other side.
6. Go to section 5 Connecting to a rack.

5.2 Connecting the KVM Switch 232

1. Connect the bracket A to the sides of the Switch using the two 6mm screws provided see figure below.

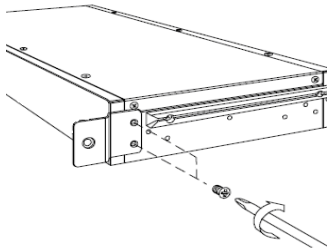

Figure 14 Connecting the bracket A to the sides of the Switch

2. Slide the Switch 232 into the rail and into the back of the SmartRack console until you hear a click. See the figure below.

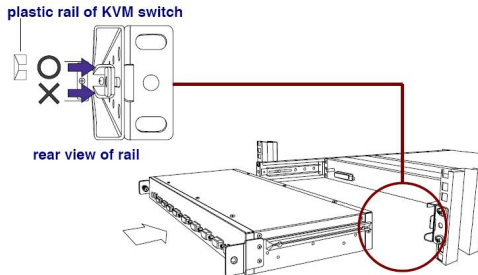

Figure 15 Slide switch into back of SmartRack

3. Secure the Switch 232 to the rail by inserting the thumbscrews through the bracket and into the rail and tightening them, see Figure 16.

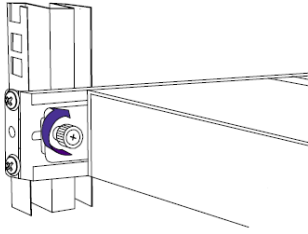

Figure 16 Tightening the thumbscrews

6. The SmartRack Switch system configuration

You connect servers to the SmartRack 232 via ROCs. Figure 17 illustrates the basic configuration of the 232 Switch.

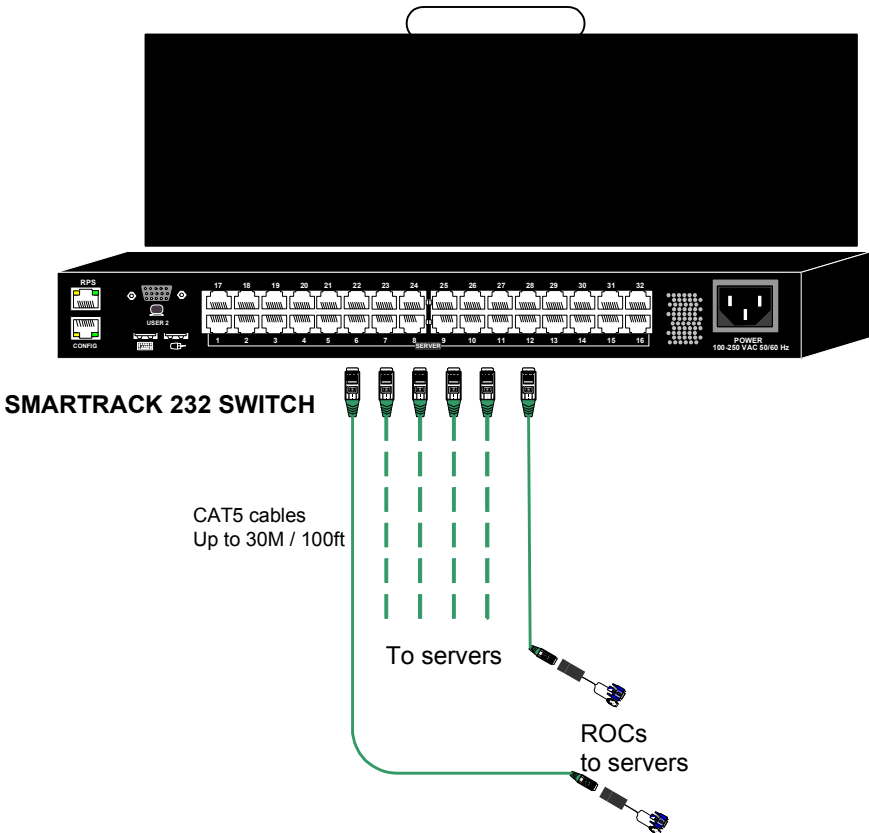

Figure 17 SmartRack 232 Switch system configuration

6.1 The KVM Switch 232

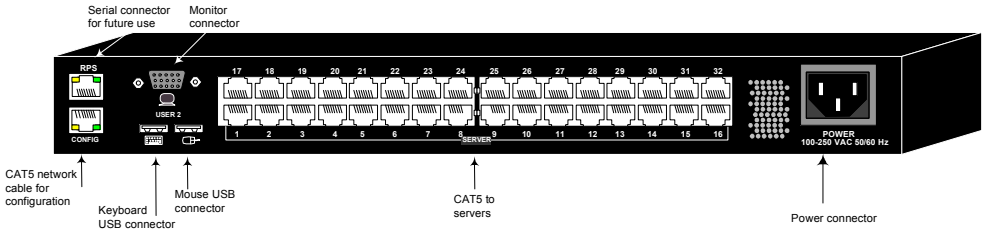

Figure 18 232 Switch ports

6.1.1.1 Connector table

Connector	Function
CONFIG	For configuring the system
RPS	For future use
KVM - User 2	For connection of second user – see softcopy User Guide
Server ports	Connect to servers via ROCs

6.2 Connecting ROCs to servers

Each computer/server is directly connected to the SmartRack switch via the appropriate ROC using CAT5 cable in a star configuration. No external power is needed at the remote ROCs. The ROCs draw their power from the computer’s keyboard port (ROC PS/2) or from the USB port (ROC USB).

6.2.1 Connecting a ROC PS/2

You can connect the ROC PS/2 to a powered on computer, but it must be in the following order:

1. Connect the Mouse connector to the computer’s Mouse port.
2. Connect the Keyboard connector to the computer’s Keyboard port.
3. Connect the Screen connector to the computer’s Video port.

Failure to connect in the above order while the server is running, may lead to the mouse malfunctioning until the server is rebooted.

6.2.2 Connecting a ROC USB

The ROC USB supports Windows 98 SE and later, MAC, SUN, SGI and all modern Linux distributions.

To connect the ROC USB:

1. Connect the Screen connector to the computer’s Video port.

2. Connect the USB connector to the computer's USB port.

6.3 Connecting the CAT5 cables

1. Connect one connector to the ROC's RJ45 port.
2. Connect the other connector to one of the SmartRack Switch Server ports.
3. Follow the above 2 steps for each computer.

6.4 Connecting the power supply

1. Connect the switch to the power supply using the Power cord provided. Only use the Power cord supplied with the unit.
2. Power on the switch.

6.5 Connecting to the Local Area Network (LAN)

Configuration is done mainly via a web interface. For this purpose connect a network cable to the CONFIG port of the Smart 232. This must be done before powering on the Smart 232.

6.6 Setting network parameters via the OSD

By default, Smart 232 boots with an automatically assigned IP address from a DHCP (Dynamic Host Configuration Protocol) server on the network. The DHCP server provides a valid IP address, gateway address and subnet mask.

You can identify the IP address from the OSD. Also where there is no DHCP server set the IP address via the OSD as follows:

1. From the local keyboard, press left **Shift** twice. The OSD Main window appears. See Figure 19.

```

MINICOM SMART SWITCH
MAIN

-- NAME                                USER  PM
01 File Server
02 Mail Server
03 AD DC
04 ESX 3i 3.5
05 Windows 2008
06 Firewall
07 Novell SuSE
08 RedHat Ent
MOVE LABEL F1      ESC-LOGOUT
TUNING             F5      F2-SETTING

```

Figure 19 OSD Main window

2. Press **F2**. The Settings window appears see Figure 20.

MINICOM SMART SWITCH SETTINGS

```

MAC ADD 00:15:9D:02:DB:5B
DHCP ENABLED
IP ADDRESS 192.168.2 .122
SUBNET MASK 255.255.255.0
GATEWAY 192.168.2 .1
HOTKEY :Shift-Shift
KEYBOARD LANGUAGE :English

Save -ESC      DDC-F10
  
```

Figure 20 Settings window

In the Settings window you navigate downwards using the Tab key. At the bottom of the window, press tab to go to the top of the window. Change settings by typing in the selected area or by pressing the spacebar – whichever is relevant.

6.6.1 Changing the Network parameters

DHCP Enable – When a DHCP server is active on the same network to which Smart 232 is connected, DHCP provides automatic IP assignment. (Displayed in the OSD).

When DHCP is disabled – (Recommended) – You can assign a fixed IP address to the Smart 232. Consult your Network Administrator regarding the use of the DHCP.

When DHCP is disabled, enter the **IP Address**, **Subnet Mask**, and **Gateway** as given by your Network Administrator.

Once the IP address is satisfactory, press ESC twice to save changes and restart the unit. You can now log into the web interface to complete the configuration, as explained below.

7. Logging into the web configuration

1. Open your web browser.
2. Type the Smart 232 system IP address – `http` or `https://IP address/` - and press **Enter**. The login page appears.
3. Type the default Administrator user name - **admin** - and password - **access** - (both lower case).

4. Press **Enter**. The web interface opens at the Targets page. See Figure 21.

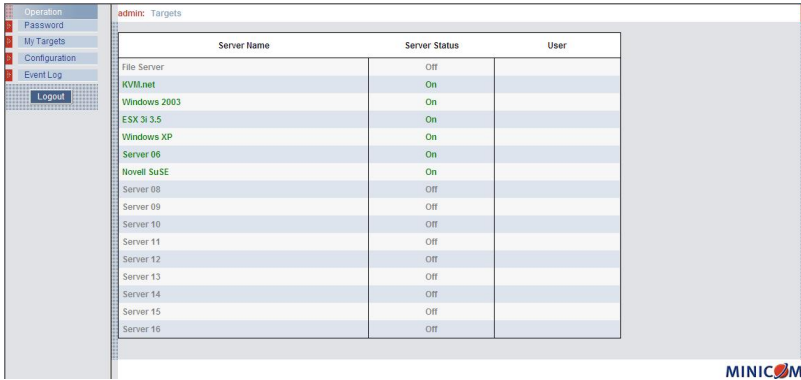

Figure 21 Targets page

From the Targets page menu an Administrator can reach the Configuration pages. From the menu, click **Configuration**. The Network > Configuration appears, see Figure 22.

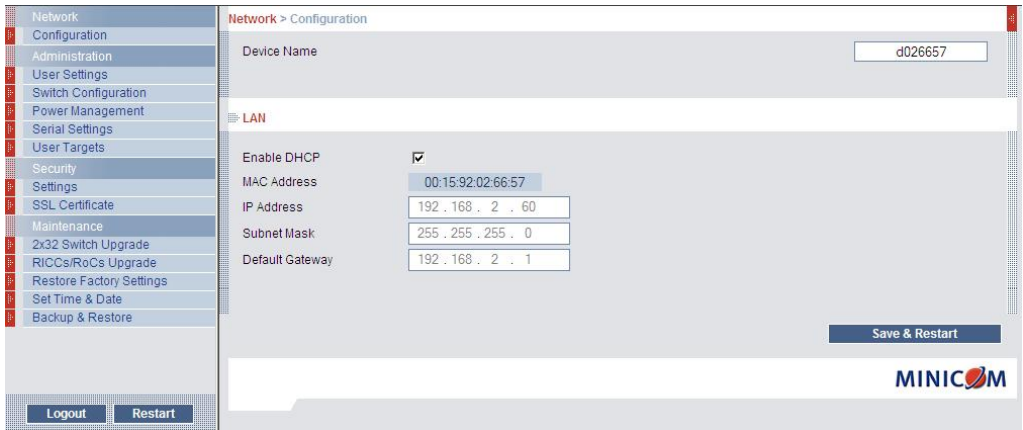

Figure 22 Network > Configuration page

7.1 Administration > Switch Configuration

Assign unique names to the servers connected to the Smart 232, so that users accessing the system can identify the servers easily.

To do so:

1. From the menu click **Switch Configuration**. The **Switch Configuration** window appears, see Figure 23.



Figure 23 Switch Configuration

- In the **Server Name** section change the name of the connected servers by selecting the server name and typing a new name. Click to save changes.

8. Operating the SmartRack 232 system

Switch between the connected computers via the OSD (On Screen Display).

The OSD is also the place to adjust various settings as explained below.

8.1 Displaying the OSD

To display the OSD:

Press **Shift** twice. The OSD Main window appears. See Figure 24.

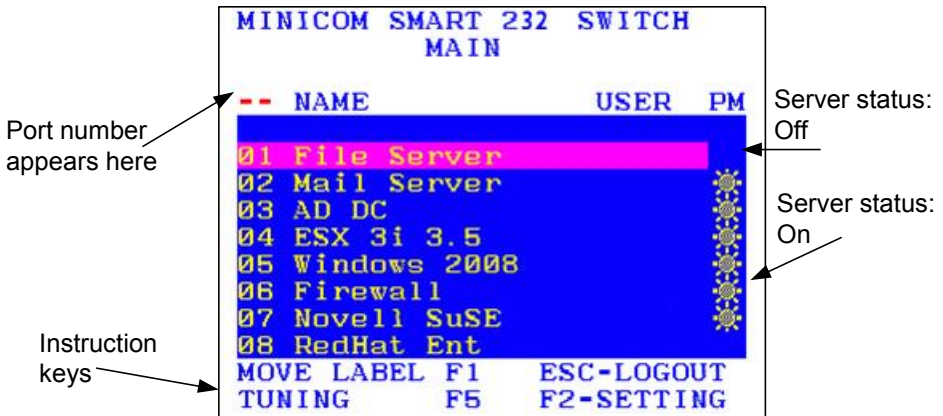

Figure 24 OSD Main window

8.1.1 Navigating the OSD

To navigate up and down use the Up and Down arrow keys.

To exit the OSD or return to a previous window within the OSD press **Esc**.

8.1.2 Selecting a computer

To select a computer:

1. Navigate to the desired computer line.
Or, type the 2-digit port number of the desired computer.
2. Press **Enter**. The selected computer is accessed. A confirmation label appears showing which computer is accessed.

To complete the initial setup and for more detailed operating instructions please see the softcopy User Guide on the supplied CD or on our website
<http://www.minicom.com/supportuserguides.htm>