

# SmartRack

## Quick Installation Guide



[www.minicom.com](http://www.minicom.com)

International HQ

Jerusalem, Israel

Tel: + 972 2 535 9666

[minicom@minicom.com](mailto:minicom@minicom.com)

North American HQ

Linden, NJ, USA

Tel: + 1 908 486 2100

[info.usa@minicom.com](mailto:info.usa@minicom.com)

European HQ

Dübendorf, Switzerland

Tel: + 41 44 823 8000

[info.europe@minicom.com](mailto:info.europe@minicom.com)

Technical support - [support@minicom.com](mailto:support@minicom.com)

## 1. Introduction

The SmartRack from Minicom is a slim, rack mountable console drawer. The SmartRack can be used as a stand alone unit or connected to a 16 port KVM Switch or 16 port KVM IP switch. Occupying just 1U of rack space, it's the neat, space-saving way to control your data rack. It comes with all the hardware you need to mount it, and is easy to install.

You can access and control up to 16 multi-platform computers from one KVM (keyboard video mouse) console.

To access servers, just slide out the drawer and flip up its top to display the large, high resolution 17" TFT LCD display.

The display is (VGA/SVGA/XGA/SXGA compatible) with front-panel high-quality controls and Touchpad for easy adjustment. When not in use, the keyboard can be concealed by closing the top.

## 2. System components

The SmartRack system can consist of:

SmartRack console drawer (Standalone).

Or SmartRack console drawer + SmartRack 116 Switch.

Or SmartRack console drawer + SmartRack Switch 116IP Switch.

## 3. Hardware kit contents

Rail with front and rear bracket x 2,  
for rack depth of 614 ~ 800 mm.  
Right and left sides are different.

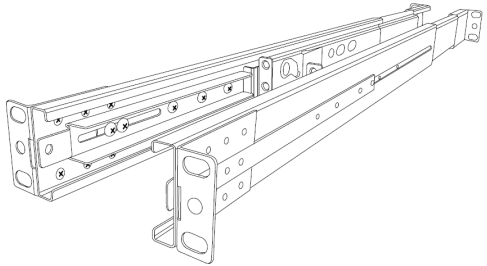

Long bracket x 2. (For increased rack  
depth of 905 ~ 990mm)

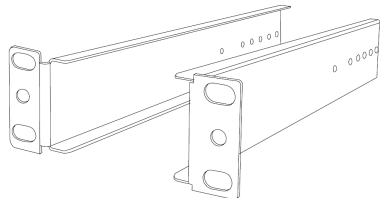

Short bracket x 2



Bracket attachment x 2



**Note!** The short bracket and bracket attachment for a rack depth of 504~ 614 mm and without a KVM switch connected to the drawer.

Flat screws x 6 (for rail mount to console body) 

Screws x 6 

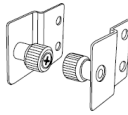

Bracket A with thumbscrew x 2

Screws x4 



Keys x 2.

## 4. Avoiding general rack mounting problems

### **Elevated operating ambient temperature**

The operating ambient temperature of the rack environment may be greater than the room ambient when installing into a closed or multi-unit rack assembly. So install the equipment in an environment compatible with the maximum rated ambient temperature.

### **Reduced airflow**

Install the equipment in a rack in such a way that the amount of airflow required for safe operation is not compromised.

### **Mechanical loading**

Mount the equipment in the rack in such a way that a hazardous condition is not achieved due to uneven mechanical loading.

### **Circuit overloading**

When connecting the equipment to the supply circuit, consider the effect that overloading of circuits might have on over-current protection and supply wiring.

Reliable earthing of rack-mounted equipment should be maintained. Give attention to supply connections other than direct connections to the branch circuit (e.g. use of power strips).

## 5. Connecting to a rack

**Note! For increased rack depth of 905 ~ 990mm, first change the bracket, see section 6 on page 5.**

Note! The illustrations below show the connections to one side of the SmartRack. The connections are the same for the other side.

1. Move the rail until two screws appear, see Figure 1.

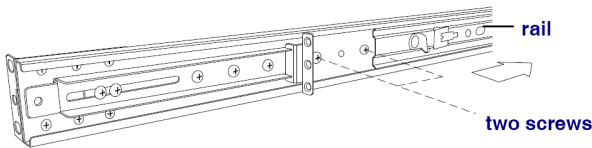

**Figure 1 Exposing the 2 screws**

2. Loosen slightly the 7 screws as shown below.

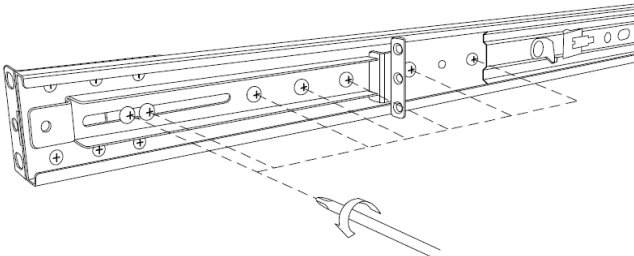

**Figure 2 Loosen 7 screws**

3. Adjust the rear bracket to fit your cabinet, see below.

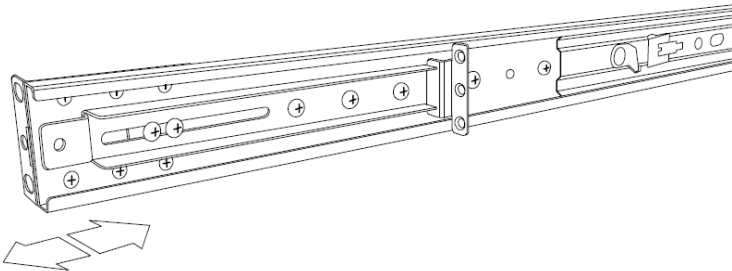

**Figure 3 Adjusting the bracket**

4. Install the front and rear bracket onto the cabinet, see figure below.

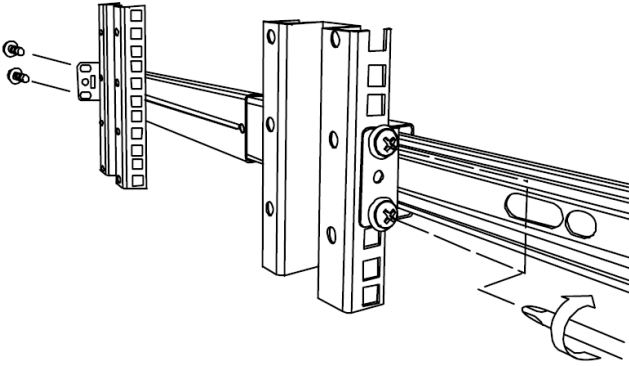

**Figure 4** Installing front and rear bracket on cabinet

5. Tighten the 7 screws as shown below.

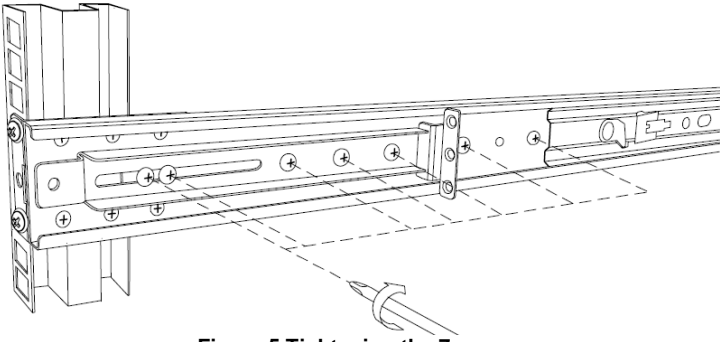

**Figure 5** Tightening the 7 screws

6. Repeat the steps above to connect the other rail to the other side of the rack.
7. Slide the SmartRack console between the rails as shown below.

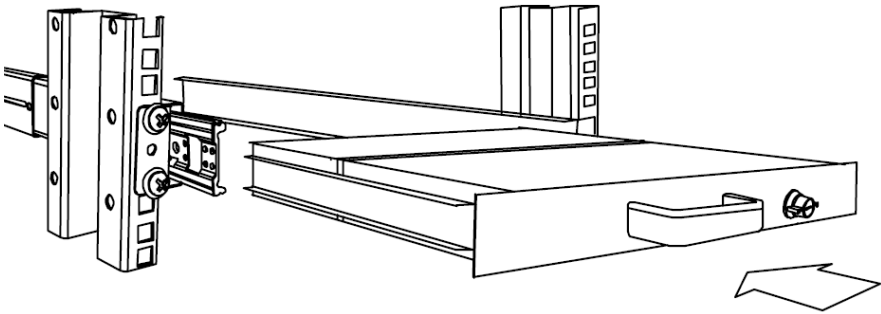

**Figure 6** Sliding the SmartRack between the rails

8. Unlock and pull both left and right rail–lock switches together – see below – and push the console all the way into the rack.

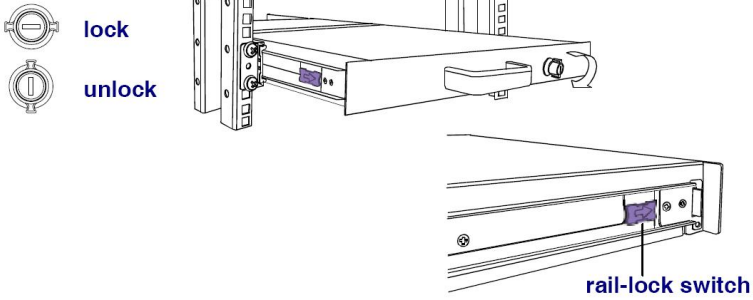

**Figure 7 Rail-lock switch**

9. Connect three flat screws to the rear of the console on both sides. See figure below.

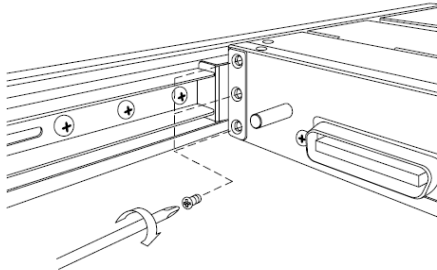

**Figure 8 Connecting three flat screws to the rear of the console**

The console now sits snugly in the rack, see Figure 9.

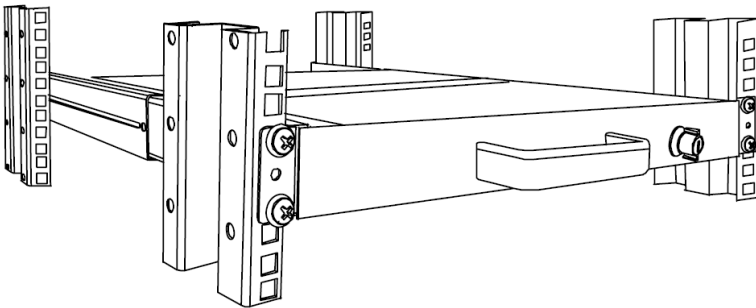
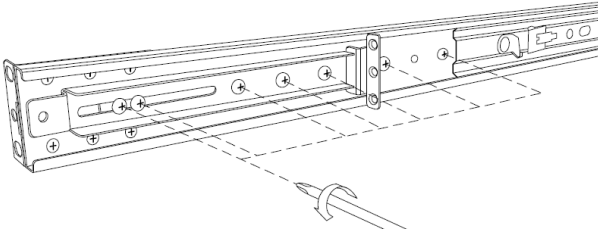

**Figure 9 Console in the rack**

6. Using the longer bracket for rack depth of 905 ~ 990mm

To replace the bracket with the longer bracket:

1. Loosen the 7 screws as shown below.



**Figure 10 Loosening the 7 screws**

Remove the six (different) screws as shown below.

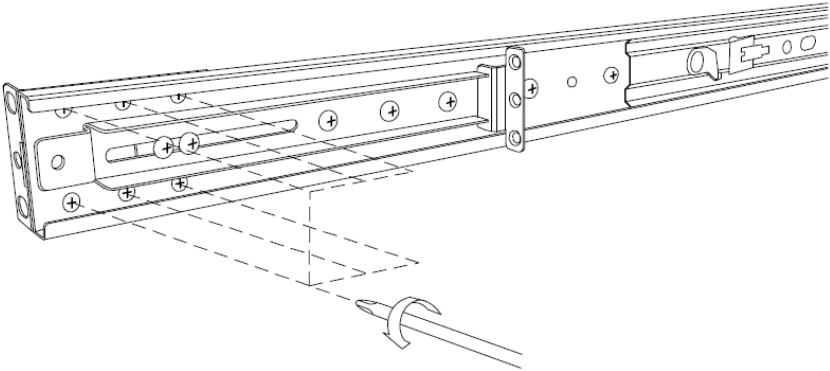

**Figure 11 Removing the six screws**

2. Take the rear bracket out, see below.

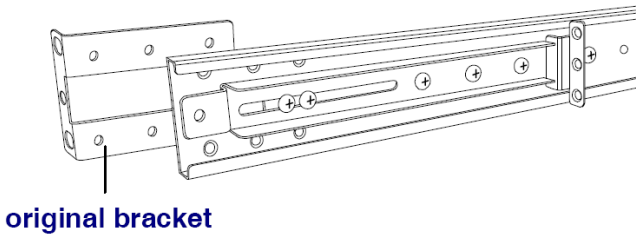

**Figure 12 Taking the rear bracket out**

3. Insert the long bracket into the rail then adjust the bracket to fit your cabinet. Tighten at least 2~3 screws along the length you need. See Figure 13.

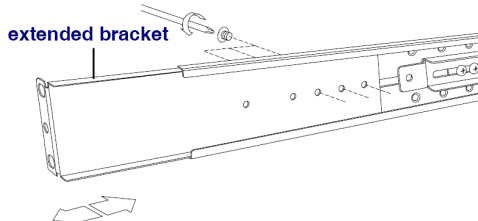

**Figure 13 Inserting and tightening the long bracket**

4. Repeat the above steps for the other side.

5. Go to section 5 Connecting to a rack.

## 7. Connecting the Switch 116 or 116IP

1. Connect the bracket A to the sides of the Switch using the two 6mm screws provided see figure below.

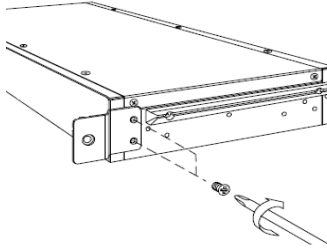

**Figure 14 Connecting the bracket A to the sides of the Switch**

2. Slide the Switch 116 into the rail and into the back of the SmartRack console until you hear a click. See the figure below.

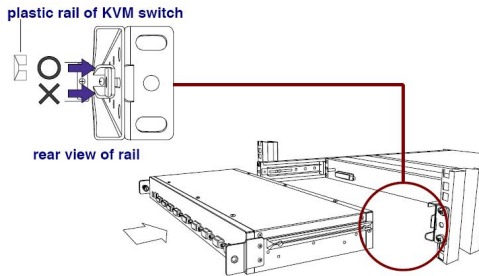

**Figure 15 Slide switch into back of SmartRack**

3. Secure the Switch 116 to the rail by inserting the thumbscrews through the bracket and into the rail and tightening them, see Figure 16.

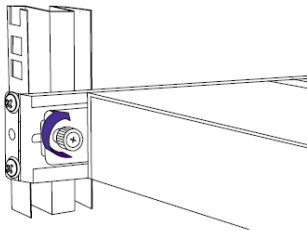

**Figure 16 Tightening the thumbscrews**

## 8. Pre-installation guidelines

- Switch off all computers
- Place cables away from fluorescent lights, air conditioners, and machines that are likely to generate electrical noise
- Ensure that the maximum distance between each computer and the SmartRack Switch, does not exceed 10m/33ft for RICCs and 30m/100ft for ROCs

## 9. The SmartRack Switch system configuration

You connect servers to the 116 and 116IP switches via ROCs or RICCs. Figure 17 and Figure 18 illustrate the basic configuration of the 116 and 116IP system.

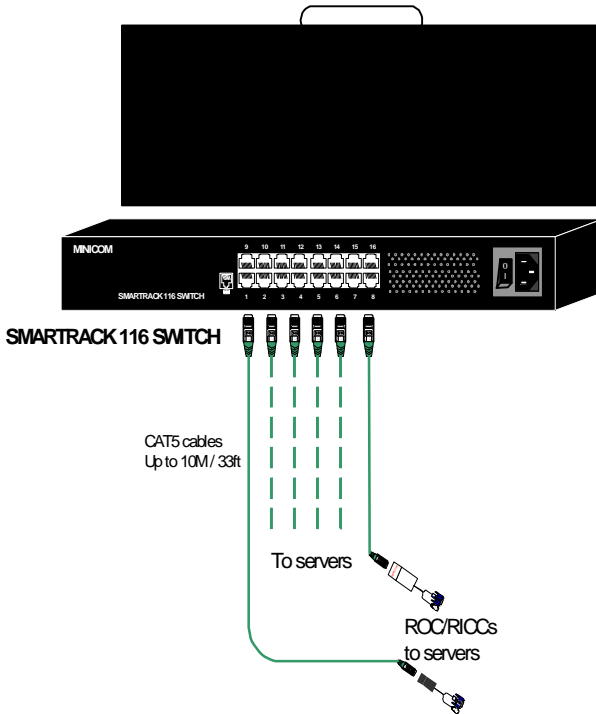

Figure 17 SmartRack 116 Switch system configuration

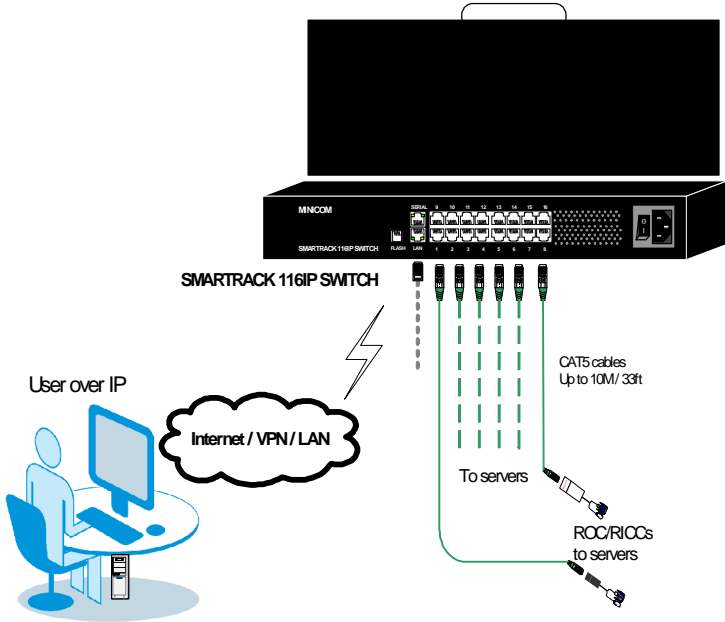

Figure 18 SmartRack 116IP Switch system configuration

## 10. The 116 and 116IP switches

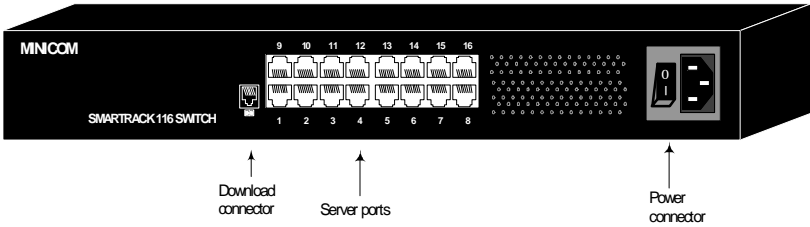

Figure 19 116 Switch ports

### Connector table

Connector	Function
Download	To update firmware of the OSD, Switch, RICC's and ROCS.
Server ports	Connect to servers via ROC/RICC's

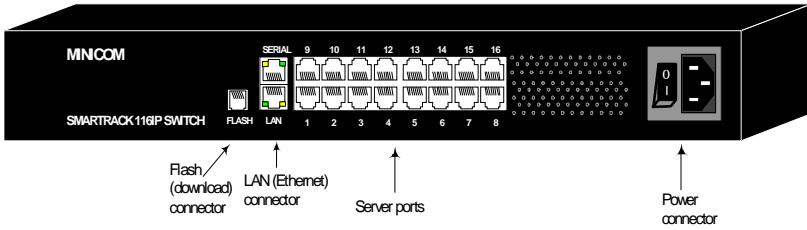

Figure 20 116IP Switch ports

Connector table

Connector	Function
Serial	This port is for future Serial functionality
Flash	To update firmware of the analogue part of the 116 IP Switch system - OSD, Switch, RICCs and ROCs.
LAN	Connect to 10/100 Mbit Ethernet. Yellow Led illuminates when connected to LAN. Green LED illuminates when a remote session is in progress
Server ports	Connect to servers via ROC/RICCs

## 11. Connecting ROC or RICC to servers

Each computer/ server is directly connected to the SmartRack switch via the appropriate ROC or RICC using CAT5 cable in a star configuration. The system can contain a mixture of ROCs and RICCs. No external power is needed at the remote ROC/RICCs. The ROC/RICCs draw their power from the computer's keyboard port (ROC/RICC PS/2) or from the USB port (ROC/RICC USB). The figures below illustrate the ROC PS/2 and ROC USB.

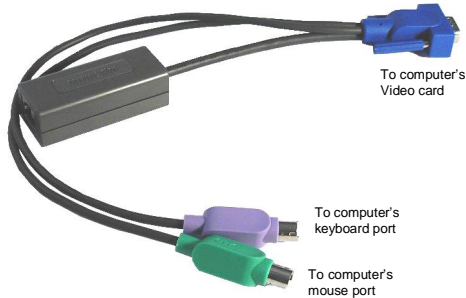

**Figure 21 ROC PS/2**

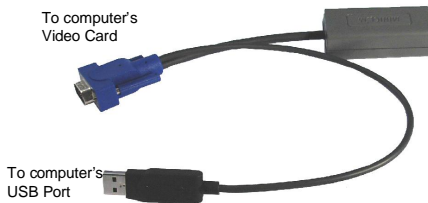

**Figure 22 ROC USB (SUN)**

### Connecting a ROC/RICC PS/2

The connections for ROC/RICC PS/2 are exactly the same. Figure 23 illustrates the RICC PS/2.

You can connect the ROC/RICC PS/2 to a powered on computer, but it must be in the following order:

1. Connect the Mouse connector to the computer's Mouse port.
2. Connect the Keyboard connector to the computer's Keyboard port.
3. Connect the Screen connector to the computer's Video port.

Failure to connect in the above order while the server is running, may lead to the mouse malfunctioning until the server is rebooted.

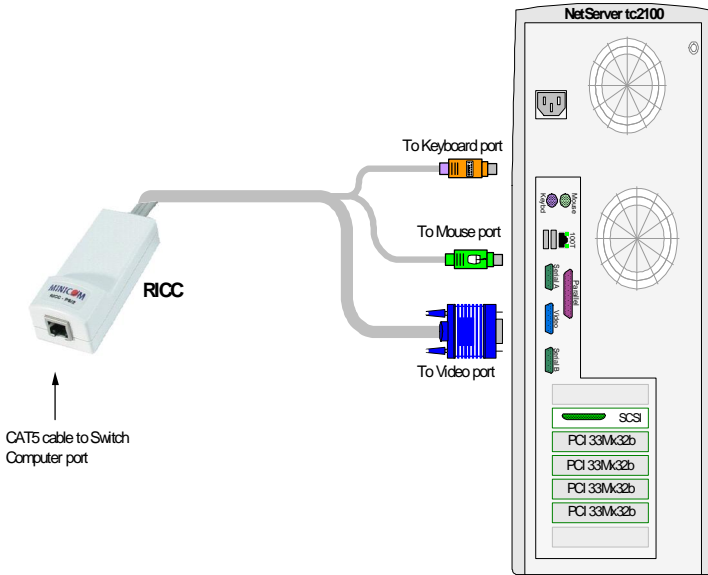

Figure 23 RICC PS/2 connections

### Connecting a ROC/RICC USB

The ROC/RICC USB supports Windows 98 SE and later, MAC, SUN, SGI and all modern Linux distributions. The connections for ROC/RICC USB are exactly the same. Figure 24 illustrates the RICC USB and its connections.

To connect the ROC/RICC USB:

1. Connect the Screen connector to the computer's Video port.
2. Connect the USB connector to the computer's USB port.

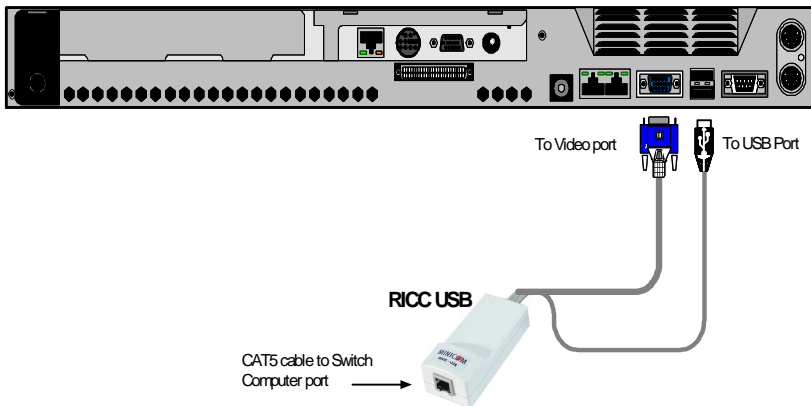

Figure 24 RICC USB

## 12. Connecting the CAT5 cables

1. Connect one connector to the ROC/RICC's RJ45 port.
2. Connect the other connector to one of the SmartRack Switch Server ports.
3. Follow the above 2 steps for each computer.

## 13. Connecting to the network

For the SmartRack 116IP Switch, connect the network cable to the LAN port. This must be done before powering on the SmartRack 116IP Switch.

## 14. Connecting the power supply

1. Connect the switch to the power supply using the Power cord provided. Only use the Power cord supplied with the unit.
2. Power on the switch and the computers.

## 15. Operating the SmartRack Switch system

For the SmartRack 116 switch go to the SmartRack 116 switch Operating Guide.

For the SmartRack 116IP switch go to the SmartRack 116IP switch Operating Guide.

## Regional Offices

### Germany

Kiel

Tel: + 49 431 668 7933

[info.minicom-germany@minicom.com](mailto:info.minicom-germany@minicom.com)

### England

Tel: + 44 121 288 0608

[info.uk@minicom.com](mailto:info.uk@minicom.com)

### France

Vincennes

Tel: + 33 1 49 57 00 00

[info.france@minicom.com](mailto:info.france@minicom.com)

### China

Beijing

Tel: +86 21 6445 3181

[Info.china@minicom.com](mailto:Info.china@minicom.com)

### Italy

Rome

Tel: + 39 06 8209 7902

[info.italy@minicom.com](mailto:info.italy@minicom.com)

### Asia Pacific / S. Korea

Tel: +972 2 535 9618

[info.ap@minicom.com](mailto:info.ap@minicom.com)

[www.minicom.com](http://www.minicom.com)

