

Smart CAT5 Switch

8 and 16 Port

User Guide



www.minicom.com

International HQ

Jerusalem, Israel
Tel: + 972 2 535 9666
minicom@minicom.com

North America

Linden, NJ, USA
Tel: + 1 908 486 2100
info.usa@minicom.com

Europe

Dübendorf, Switzerland
Tel: + 41 44 823 8000
info.europe@minicom.com

Technical support - support@minicom.com

Table of Contents

1. Welcome	3
2. Introduction.....	4
3. Features	4
4. System components	4
5. Compatibility	4
6. The Smart CAT5 system configuration.....	5
7. The Smart CAT5 models	5
8. Pre-installation guidelines	6
9. Connecting the Smart CAT5 system	6
10. Connecting the power supply.....	9
11. Resetting the Switch.....	9
12. Avoiding general rack mounting problems	9
13. Rack mounting the Smart CAT5	10
14. Rack mounting the RICC's.....	11
15. Cascading Smart CAT5 switches	12
16. Operating the Smart CAT5 system	13
17. The keyboard hotkeys	13
18. Displaying the OSD.....	13
19. Navigating the OSD.....	14
20. Selecting a computer.....	14
21. The OSD settings (F2).....	14
22. The General settings.....	15
23. F7 Defaults	18
24. The Ports settings.....	18
25. The Time settings	19
26. Users	20
27. Security	21
28. The OSD HELP window – F1.....	21
29. Scanning computers– F4.....	22
30. Tuning – F5	22
31. Moving the label – F6.....	22
32. Sending monitor emulation information to RICC's – F10.....	23
33. Using the Control software	23
34. Control software system requirements	24
35. Connecting the RS232 Serial cable	24
36. Installing and running the Control software.....	25
37. Computer icons.....	26
38. Communication Error	26
39. The View menu.....	26
40. Selecting a computer.....	27
41. The toolbar buttons	27

42. Get Status	27
43. Read Configuration.....	27
44. Write Configuration.....	27
45. Renaming a computer.....	28
46. The Edit menu	28
47. Logo and Passwords	28
48. Settings	29
49. Loading a saved configuration	30
50. Reminder!.....	30
51. The factory default settings.....	30
52. Password protection.....	30
53. Upgrading the Smart CAT5 firmware.....	31
54. System requirements for the Smart CAT5 Update software	31
55. Connecting the Smart CAT5 system	31
56. Connecting the RS232 Serial cable	32
57. Installing the software	32
58. Starting and configuring the Smart CAT5 Update.....	32
59. Verifying the version numbers	33
60. Obtaining new firmware.....	34
61. Updating the firmware	35
62. Reset	35
63. RICC SUN keyboard emulation.....	36
64. Troubleshooting tips.....	36
65. USB / SUN Combo keys	37
66. Technical specifications	38
67. User guide feedback.....	39

1. Welcome

Thank you for buying the Smart CAT5 Switch system. This system is produced by Minicom Advanced Systems Limited.

Technical precautions

This equipment generates radio frequency energy and if not installed in accordance with the manufacturer's instructions, may cause radio frequency interference.

This equipment complies with Part 15, Subpart J of the FCC rules for a Class A computing device. This equipment also complies with the Class A limits for radio noise emission from digital apparatus set out in the Radio Interference Regulation of the Canadian Department of Communications. These above rules are designed to provide reasonable protection against such interference when operating the equipment in a commercial environment. If operation of this equipment in a residential area causes radio frequency interference, the user, and not Minicom Advanced Systems Limited, will be responsible.

Changes or modifications made to this equipment not expressly approved by Minicom Advanced Systems Limited could void the user's authority to operate the equipment.

Minicom Advanced Systems Limited assumes no responsibility for any errors that appear in this document. Information in this document is subject to change without notice.

No part of this document may be reproduced or transmitted in any form or by any means, electronic or mechanical, for any purpose, without the express written permission of Minicom Advanced Systems Limited.

© 2007 Minicom Advanced Systems Limited. All rights reserved.

Trademarks

PS/2 is a registered trademark of International Business Machines Corporation. All other trademarks and registered trademarks are the property of their respective owners.

2. Introduction

Access and control multiple multi-platform computers from one Keyboard Video Mouse (KVM) console with the Smart CAT5 Switch (Smart CAT5) system. The Smart CAT5 comes in 8 and 16 port models. Connect up to 8 computers to the 8 port model, and up to 16 to the 16 port model.

3. Features

- Hot-Swap - disconnect and reconnect computers without rebooting
- Scan-mode operation with variable time interval
- 1U Rack mountable
- Operate the system using an On Screen Display (OSD) or Control software or front panel push buttons or keyboard hotkeys
- Create multi-level cascade arrangements. For example by cascading the Smart CAT5 16 Port model, connect up to up to 256 computers in the system
- The computers can be placed up to 10m/33ft from the Smart CAT5
- Multi-platform — supports PS/2, SUN, and USB computers/servers

4. System components

The Smart CAT5 system consists of:

- Smart CAT5 Switch 8 or 16 port
- Remote Interface Connection cables (RICCs) – PS/2, SUN, USB
- CAT5 cables (1.5m provided)
- RS232 Serial cable
- Rack mounts for the Smart CAT5 and the RICCs

5. Compatibility

The Smart CAT5 is compatible with:

- PS/2, SUN and USB computers/servers
- VGA, SVGA, or XGA monitors
- DOS, Windows (3X, 9X, 2000, NT4, ME, XP, 2003 Server) LINUX, UNIX, QNX, SGI, FreeBSD, BeOS, Open VMS, Novell 3.12-6, Alpha UNIX, HP UX, SUN

6. The Smart CAT5 system configuration

Figure 1 illustrates the basic configuration of the Smart CAT5 system.

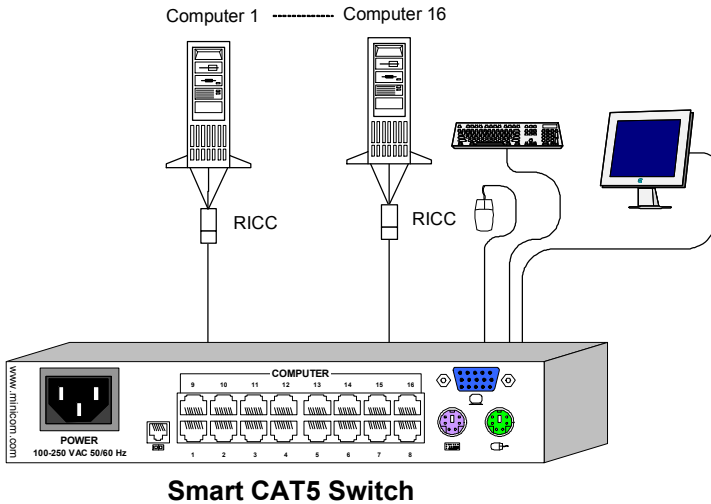

Figure 1 The Smart CAT5 system configuration

7. The Smart CAT5 models

Figure 2 illustrates the front panel of the Smart CAT5 16 port model. The 8 port model is the same but with only 8 columns of LEDs.

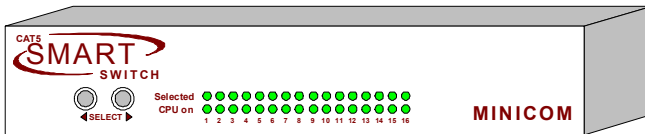

Figure 2 Smart CAT5 front panel

The figure below illustrates the rear panel of the Smart CAT5 16 port unit. The 8 port model is the same but with only 8 Computer ports.

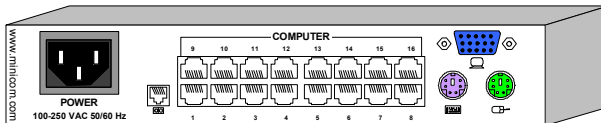

Figure 3 Smart CAT5 16 port rear panel

8. Pre-installation guidelines

- Switch off all computers
- Place cables away from fluorescent lights, air conditioners, and machines that are likely to generate electrical noise
- Ensure that the maximum distance between each computer and the Smart CAT5, does not exceed 10m/33ft

9. Connecting the Smart CAT5 system

Connect each computer to the Smart CAT5 system using the appropriate RICC and CAT5 cables. Figure 4 illustrates the Smart CAT5 system connections with the appropriate RICC connected to a PS/2, SUN and USB computer/server.

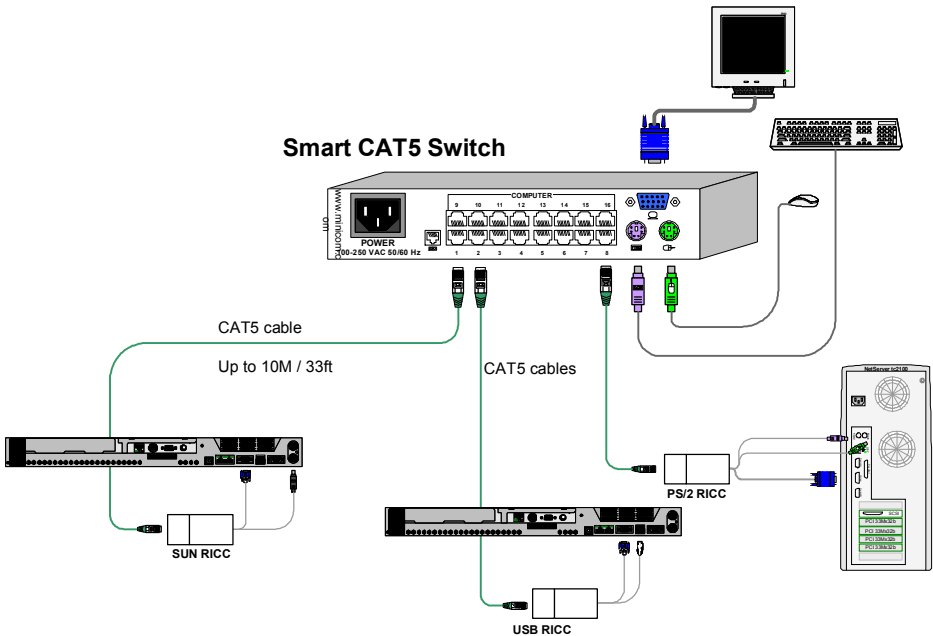

Figure 4 Smart CAT5 system connections

The RICCs

The RICCs draw their power from the computer's keyboard port (RICC PS/2, SUN) or from the USB port (RICC USB).

Connecting a PS/2 RICC

Figure 5 illustrates the PS/2 RICC.

You can connect the PS/2 RICC to a powered on computer, but it must be in the following order:

1. Connect the Mouse connector to the computer's Mouse port.
2. Connect the Keyboard connector to the computer's Keyboard port.
3. Connect the Screen connector to the computer's Video card.

Failure to connect in the above order while the server is running, may lead to the mouse malfunctioning until the server is rebooted.

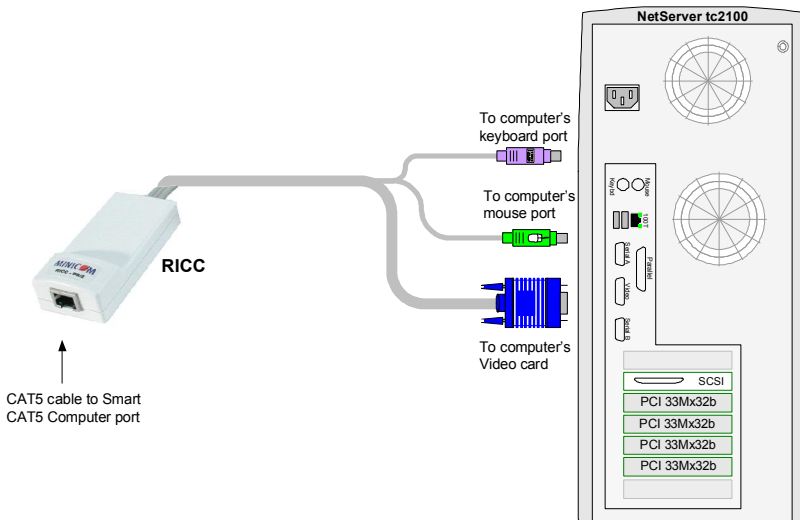

Figure 5 PS/2 RICC

Connecting a SUN RICC

Figure 6 illustrates the SUN RICC and its connections.

To connect the SUN RICC:

1. Connect the Screen connector to the computer's Video card.
2. Connect the Keyboard connector to the computer's Keyboard port.

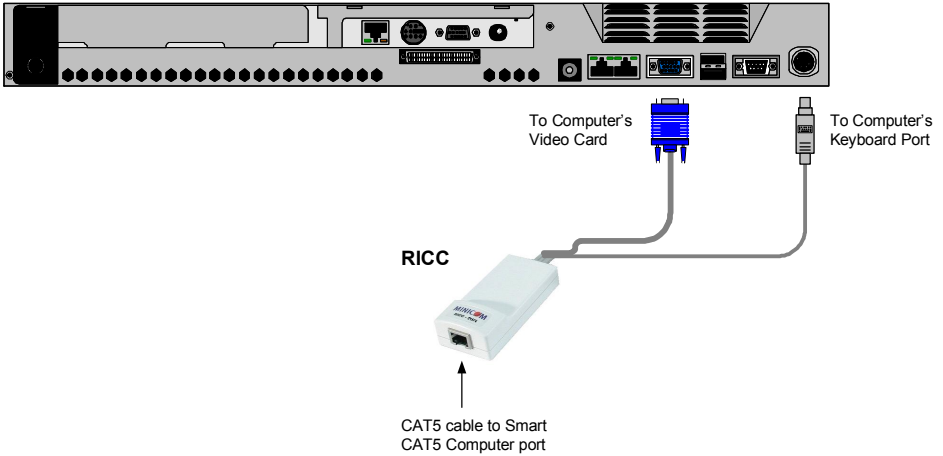

Figure 6 SUN RICC

Connecting a USB RICC

The RICC USB supports Windows 98 SE and later, MAC, SUN and SGI. Figure 7 illustrates the USB RICC and its connections.

To connect the USB RICC:

1. Connect the Screen connector to the computer's Video card.
2. Connect the USB connector to the computer's USB port.

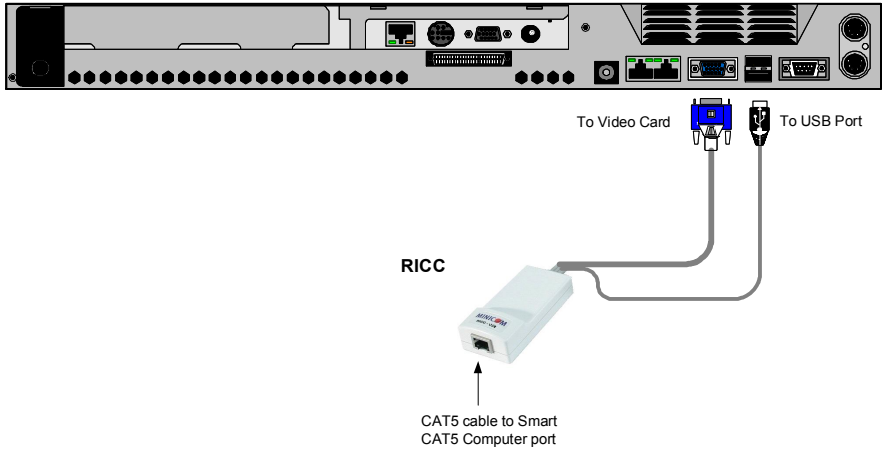

Figure 7 USB RICC

Connecting the CAT5 cables

1. Connect one connector to the RICCs RJ45 port.
2. Connect the other connector to one of the Smart CAT5's Computer ports.
3. Follow the above 2 steps for each computer.

Connecting the KVM console

To connect a KVM console to the Smart CAT5:

1. Connect the monitor's connector to the Smart CAT5's Monitor port.
2. Connect the keyboard's connector to the Smart CAT5's Keyboard port.
3. Connect the mouse's connector to the Smart CAT5's Mouse port.

10. Connecting the power supply

1. Connect the Smart CAT5 to the power supply using the Power cable provided. Use only power cord supplied with the unit.
2. Switch on the computers.

11. Resetting the Switch

To reset the Switch press the 2 front panel Select buttons simultaneously. The RICCs are unaffected by this reset.

Resetting can also be performed through the software – explained later.

12. Avoiding general rack mounting problems

Elevated operating ambient temperature

The operating ambient temperature of the rack environment may be greater than the room ambient when installing into a closed or multi-unit rack assembly. So install the equipment in an environment compatible with the maximum rated ambient temperature.

Reduced airflow

Install the equipment in a rack in such a way that the amount of airflow required for safe operation is not compromised.

Mechanical loading

Mount the equipment in the rack in such a way that a hazardous condition is not achieved due to uneven mechanical loading.

Circuit overloading

When connecting the equipment to the supply circuit, consider the effect that overloading of circuits might have on over-current protection and supply wiring.

Reliable earthing of rack-mounted equipment should be maintained. Give attention to supply connections other than direct connections to the branch circuit (e.g. use of power strips).

13. Rack mounting the Smart CAT5

Length of the screws used for connection of the bracket to the Smart CAT5 unit shall not exceed 5 mm.

Use the L-shaped brackets and screws provided to mount the Smart CAT5 on a server rack as illustrated below.

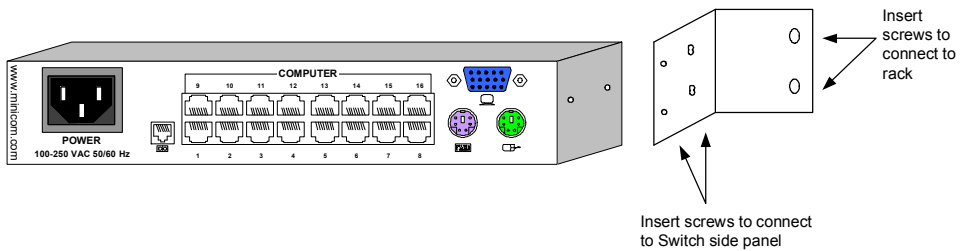

Figure 8 Connecting the L-shaped bracket

14. Rack mounting the RICCs

You can attach the RICCs to a server rack or computer using the Velcro strips provided. Or connect it using the bracket provided.

The figure below illustrates the bracket.

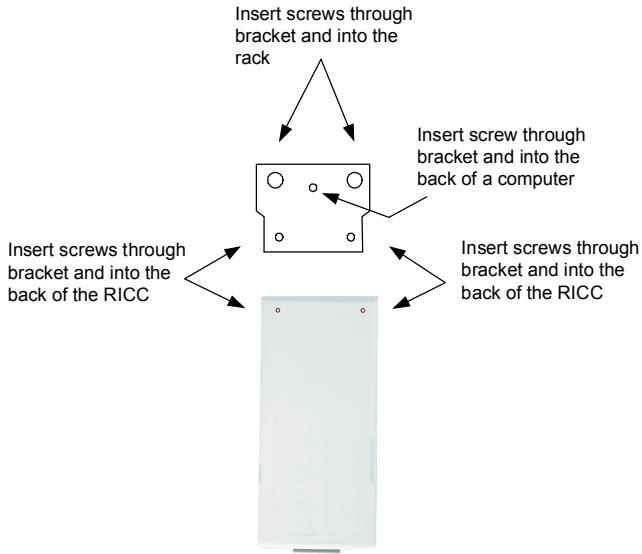

Figure 9 Rack mounting the RICC

15. Cascading Smart CAT5 switches

You can cascade the Smart CAT5 system. You do so by connecting the lower level Smart CAT5 Switches to RICCs. Follow the connections as illustrated in the figure below.

With the Smart CAT5 16 Port model, connect up to up to 256 computers through cascading.

A lower level Switch must have a different hotkey to display its OSD than a higher level switch. Changing the OSD display hotkey is explained on page 16 below.

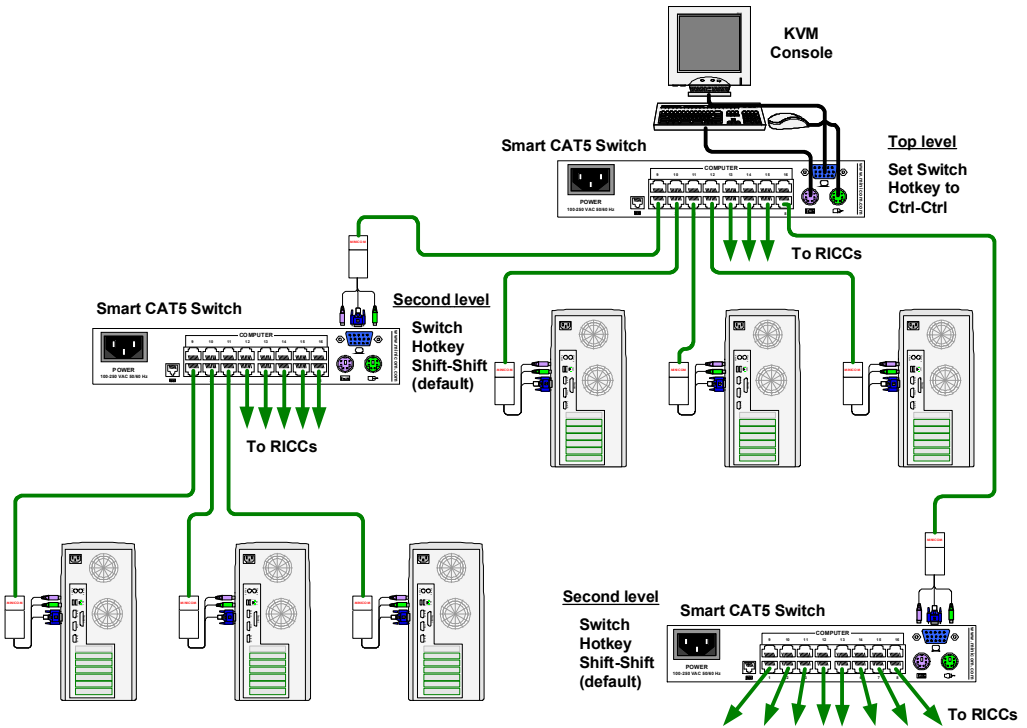

Figure 10 Cascading Smart CAT5 switches

16. Operating the Smart CAT5 system

Switch between the connected computers by either

- The front panel Select buttons
- Keyboard hotkeys
- The OSD (On Screen Display) or Control software

The OSD is also the place to adjust various settings as explained below.

When switching computers the illuminated LED of the top bank indicates which computer is currently selected.

17. The keyboard hotkeys

To switch to the next computer forwards press **Shift** then, +. Release **Shift**, before pressing +.

To switch to the next computer backwards press **Shift** then, -. Release **Shift**, before pressing -.

Note! With a US English keyboard you can use the + key of the alphanumeric section or of the numeric keypad. With a Non-US English keyboard only use the + key of the numeric keypad.

18. Displaying the OSD

To display the OSD:

Press **Shift** twice. The OSD Main window appears. See Figure 11. Lines with blue text show active computers. Lines with grey text show inactive computers.

The Type column indicates whether a computer “C” or another switch “S” is connected to the port.

M I N I C O M				S M A R T C A T 5 S W I T C H			
M A I N							
---	N A M E						T Y P E
0 1	C O M P U T E R	0 1					C
0 2	C O M P U T E R	0 2					C
0 3	C O M P U T E R	0 3					C
0 4	S W I T C H	0 4					S
0 5	C O M P U T E R	0 5					C
0 6	C O M P U T E R	0 6					C
0 7	C O M P U T E R	0 7					C
0 8	C O M P U T E R	0 8					C
F 1 - H E L P				F 2 - S E T T I N G S			

Port number appears here

Instruction keys

C=computer
S=switch

Figure 11 The OSD Main window

19. Navigating the OSD

To navigate up and down use the Up and Down arrow keys.

To jump from one column to the next (when relevant) use the Tab key.

To exit the OSD or return to a previous window within the OSD press **Esc**.

20. Selecting a computer

To select a computer:

1. Navigate to the desired computer line.
2. Press **Enter**. The selected computer is accessed. A confirmation label appears showing which computer is accessed.

Note! When the OSD is displayed you cannot select computers using the front panel Select buttons or the keyboard hotkeys.

21. The OSD settings (F2)

Press **F2**. The OSD Settings window appears see Figure 12.

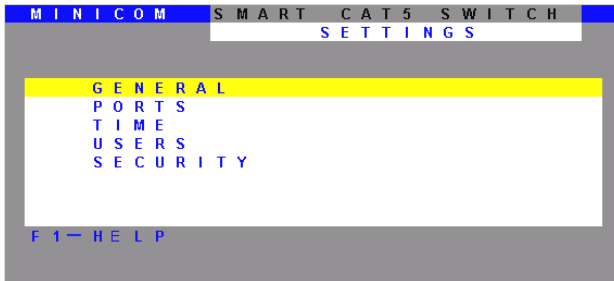

Figure 12 The Settings window

Note! When the OSD is password protected (explained below) only the Administrator has access to the **F2** settings window.

22. The General settings

With the GENERAL line highlighted, press **Enter**. The General settings window appears see Figure 13.

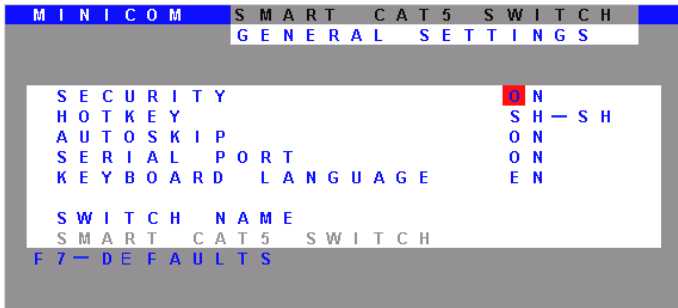

Figure 13 General Settings window

From this window you can do the following:

Security

The OSD comes with an advanced password security system that contains 3 different security levels. Each security level has different access rights to the system.

These levels are as follows:

Administrator (Status A)

The Administrator can:

- Set and modify all Passwords and security profiles
- Fully access any computer
- Use all OSD functions

Supervisor (Status S)

The Supervisor can:

- Fully access any computer
- Access the following OSD functions only –**F4** Scan, **F5** Tune and **F6** Moving the Confirmation label.

User (Status U)

There are 6 different Users in the Smart CAT5 system. Each User has a Profile set by the Administrator that defines the access level to different computers. There are 3 different access levels; these are explained on page 20.

Activating password protection

By default OSD access is not password protected. Only the Administrator can password-protect the OSD or disable password protection.

To do so:

1. In the General settings window navigate to the Security line.
2. Press the Spacebar to toggle between Security On and Off. The password box appears.
3. Type the Administrator's password (default is "admin").
4. Press **Enter**. The new security status is set.

If you forget the Administrator's password, go to www.minicom.com. From the Support menu select Smart Switches. There you will find information that explains how to restore a lost password or reset the switch to its default settings including the default password.

Displaying the OSD of cascaded switches

When you have cascaded Smart CAT5 switches, a lower level Switch must have a different OSD display hotkey than a higher level switch. (See page 12.)

The hotkeys can be any of the following:

- Shift, Shift (default)
- Ctrl, Ctrl
- Ctrl, F11
- Print Screen

To change the top level hotkey:

1. Navigate to the HOTKEY line.
2. Choose a different hotkey than the **Shift, Shift** hotkey of the lower level Switches. Toggle between the options using the Spacebar.

To change a lower level hotkey:

1. Connect a keyboard and monitor to the lower level Switch and press **Shift, Shift**. Its OSD appears.
2. Press **F2** and select GENERAL. The General settings window appears.
3. Navigate to the HOTKEY line.
4. Choose a different hotkey than the hotkey of the of the top layer switch. Toggle between the options using the Spacebar.

Note! When a lower level Switch hotkey is changed, there is an adjustment to be made in the higher level Switch's OSD: This is explained on page 19-(HKEY) hotkey - Cascading.

Autoskip

When Autoskip is on, you can only access the active computers. When Autoskip is off, you can access active and inactive computers. (This includes operating the Switch via the OSD, front panel buttons or hotkeys).

To change the Autoskip setting:

1. Navigate to the Autoskip line.
2. Toggle between the options using the Spacebar.

Serial port

The Serial port is used for the Control Management program. Serial port On means the program can be used.

To change the Serial port setting:

1. Navigate to the Serial port line.
2. Toggle between the options using the Spacebar.

Changing the Keyboard language

In the OSD the names of the computers can be written in 3 different languages – English (EN), German (DE), and French (FR). The keyboard is preset to English; this can be changed as follows:

1. Navigate to the Keyboard language line.
2. Toggle between the options using the Spacebar.

Editing the Switch name

You can substitute up to 18 characters in the line. A space constitutes a character. When there is more than one switch in the system give each Switch's OSD a different name.

23.F7 Defaults

Press F7 to return the OSD to the factory default settings. Note! All changes made will be removed.

24.The Ports settings

From the General Settings, return to the Settings window by pressing **Esc**. Navigate to the Ports line and press **Enter**. The Ports settings window appears see Figure 14.

	NAME	KB	KEY
0 1	COMPUTER	0 1	PS NO
0 2	COMPUTER	0 2	U 1 NO
0 3	SWITCH	0 3	PS CLF 1 1
0 4	COMPUTER	0 4	PS NO
0 5	COMPUTER	0 5	U 2 NO
0 6	COMPUTER	0 6	U 3 NO
0 7	COMPUTER	0 7	PS NO
0 8	COMPUTER	0 8	PS NO

Figure 14 Ports Settings window

Editing the computer name

In this window you can edit the computer names with up to 15 characters. When you have a cascaded CAT5 KVM Switch connected to a Computer port give the switch a distinct name. See Figure 14.

To erase a character:

Select it and press the Spacebar. Blank spaces remain in place of the erased character.

To erase an entire line:

Place the cursor at the beginning of the line. Keep the Spacebar depressed until the line is erased.

Keyboard (KB)

By default the Keyboard mode is set to PS, which is suitable for Windows, Linux, MAC OS, SUN Solaris and most other operating systems.

For certain UNIX operating systems set the KB column as follows:

- U1 for HP UX
- U2 for Alpha UNIX, SGI, Open VMS
- U3 for IBM AIX

(HKEY) hotkey - Cascading

When there are cascaded switches, and the lower level Switch has had its OSD display hotkey changed, you must do the following:

Adjust the HKEY setting in the Ports Settings window of the higher level switch to reflect the lower level switch's new hotkey: E.g. in Figure 14 above a Smart CAT5 switch is connected to port #3 and its display hotkey is Ctrl, F11.

To reflect the new hotkey:

1. On the line to which the Switch is connected, press Tab to jump to the HKEY column.
2. Toggle between the options using the Spacebar.
3. Return to the Settings window by pressing **Esc**.

25. The Time settings

In the Settings window navigate to the Time line and press **Enter**. The Time settings window appears see Figure 15.

MINICOM		SMART CAT5 SWITCH			
TIME SETTINGS					
	NAME	SCN	LBL	T/O	
0 1	COMPUTER	0 1	0 3 0	0 3 0	0 3 0
0 2	COMPUTER	0 2	0 3 0	0 3 0	0 3 0
0 3	COMPUTER	0 3	0 3 0	0 3 0	0 3 0
0 4	COMPUTER	0 4	0 3 0	0 3 0	0 3 0
0 5	COMPUTER	0 5	0 3 0	0 3 0	0 3 0
0 6	COMPUTER	0 6	0 3 0	0 3 0	0 3 0
0 7	COMPUTER	0 7	0 3 0	0 3 0	0 3 0
0 8	COMPUTER	0 8	0 3 0	0 3 0	0 3 0

Figure 15 Time settings window

Scan (SCN) - Label (LBL) - Time out (T/O)

SCN - In the SCN column, change the scan period.

LBL - In the LBL column, change the display period of the OSD label showing which computer is currently accessed.

T/O - When password protection is activated you can automatically disable the Management keyboard, mouse and screen after a preset time of non-use. Set this Timeout period in the T/O column.

To set the above periods:

1. On the desired line press Tab to jump to the desired column.

- Place the cursor over one of the 3 digits and type a new number. Enter a leading zero where necessary. For example, type 040 for 40 seconds.

Typing 999 in the **LBL** column displays the label continuously. Typing 000 – the label will not appear.

Typing 999 in the **T/O** column disables the Timeout function. Warning! Typing 000 causes the Timeout function to work immediately. Minimum time should be not less than 005 seconds.

Typing 999 in the **SCN** column displays the screen for 999 seconds. Typing 000 – the computer screen is skipped.

26. Users

In the Settings window navigate to the Users line and press **Enter**. The Users settings window appears see Figure 16.

M I N I C O M				S M A R T C A T 5 S W I T C H		U S E R S S E T T I N G S					
N A M E						U S E R					
						1	2	3	4	5	6
0 1	C O M P U T E R	0 1				Y	Y	Y	V	N	V
0 2	C O M P U T E R	0 2				V	V	V	Y	Y	N
0 3	C O M P U T E R	0 3				V	V	V	V	V	V
0 4	C O M P U T E R	0 4				N	N	N	V	Y	Y
0 5	C O M P U T E R	0 5				V	V	N	N	N	V
0 6	C O M P U T E R	0 6				Y	Y	Y	Y	Y	Y
0 7	C O M P U T E R	0 7				Y	Y	Y	Y	Y	Y
0 8	C O M P U T E R	0 8				Y	Y	Y	Y	Y	Y

Figure 16 Users settings window

There are 3 different access levels. These are:

- Y – Full access to a particular computer. Plus access to the **F4**, **F5** and **F6** OSD functions
- V – Viewing access only, to a particular computer (No keyboard/mouse functionality)
- N – No access to a particular computer – A TIMEOUT label appears if access is attempted

To give each user the desired access level:

- Navigate to the desired computer line and User.
- Toggle between the options using the Spacebar.

27. Security

In the Settings window navigate to the Security line and press **Enter**. The Security settings window appears see Figure 17.

NAME	PASSWORD	T
ADMINISTRATOR	ADMIN	A
SUPERVISOR	S	S
USER	1	U
USER	2	U
USER	3	U
USER	4	U
USER	5	U
USER	6	U

Figure 17 Security settings window

The 'T' column on the right hand side stands for Type of password.

There can only be 1 Administrator password, 1 Supervisor password, and 6 User passwords.

To change a user name or password:

1. Navigate to the desired line and column.
2. Type a new user name / password. User authentication is done solely via the password there is no security significance to the names.

By default the User Profile settings are full access.

28. The OSD HELP window – F1

To access the HELP window press **F1**. The HELP window appears see Figure 18.

SCAN	F 4
TUNE	F 5
MOVE LABEL	F 6
NEW MONITOR — DDC 2	F 1 0
MOVE UP — DOWN	▲ ▼
SELECT COMPUTER	ENTER
CHOOSE OPTION	SPACE
NEXT COLUMN	TAB
EXIT	ESC

Figure 18 HELP window

Please note! All the functions set out in the Help window are performed from the Main window. The Help window is merely a reminder of the hotkeys and their functions.

29. Scanning computers– F4

Where necessary adjust the scan time in the Time Settings window, see above.

To activate scanning:

1. Press **Shift** twice to open the OSD.
2. Press **F4**. Your screen displays each active computer sequentially, with the Scan label appearing in the top left corner.

To deactivate scanning:

Press **F4**.

30. Tuning – F5

You can tune the image of any remote computer screen from the Select Computer window.

To adjust the screen image:

1. Navigate to the remote computer you wish to adjust.
2. Press **F5**. The screen image of the selected computer appears, together with the Image Tuning label.
3. Adjust the image by using the **Right** and **Left** Arrow keys.
4. When the image is satisfactory, press **Esc**.

Note! Picture quality is relative to distance. The further away a remote computer is from the Smart CAT5, the lower the image quality, and the more tuning needed. So place the higher resolution computers closer to the manager unit.

31. Moving the label – F6

Position the OSD label anywhere on the screen.

To position the label from the Main window:

1. Navigate to the desired computer using the **Up** and **Down** arrow keys.
2. Press **F6**. The selected screen image and Identification label appears.
3. Use the arrow keys to move the label to the desired position.
4. Press **Esc** to save and exit.

32. Sending monitor emulation information to RICCs – F10

Display Data Channel (DDC) is a VESA standard for communication between a monitor and a video adapter.

Input the DDC information of the monitor connected to the Smart CAT5 switch into the memories of all connected RICCs when first installing system.

To input the DDC information:

1. Disconnect the Video cable of all RICCs from the computers.
2. Press **Shift** twice to open the OSD.
3. Press **F10**. “Please wait” flashes a few times and disappears. The monitor’s DDC information is sent to all the RICCs.
4. Reconnect the Video cable of all RICCs.

Updating the DDC information

Update the DDC information in any of the following circumstances:

- When replacing the monitor connected to Smart CAT5 Switch
- When adding a new RICC to the system
- When reconnecting an existing RICC that was temporarily used in a different system

To update the DDC information, repeat the steps as set out above.

33. Using the Control software

As an alternative to the OSD, you can operate the system with the Control software located on our website www.minicom.com in the Support section on the Smart CAT5 Switch Upgrades page. With the OSD you operate the system and view the computer screens on the same monitor. The Control software requires 2 monitors: 1 for the software and 1 to view the computer screens.

With the Control software you can:

- View computers
- Edit OSD settings
- Save configurations for future use
- Read configurations from and write configurations to the Smart CAT5 Switch

34. Control software system requirements

- Pentium 166 or higher computer
- 16Mb RAM
- Windows 98 and later
- Free Serial port

35. Connecting the RS232 Serial cable

To run the software, connect the RS232 Serial cable to the computer containing the software, and to the Smart CAT5. See the figure below.

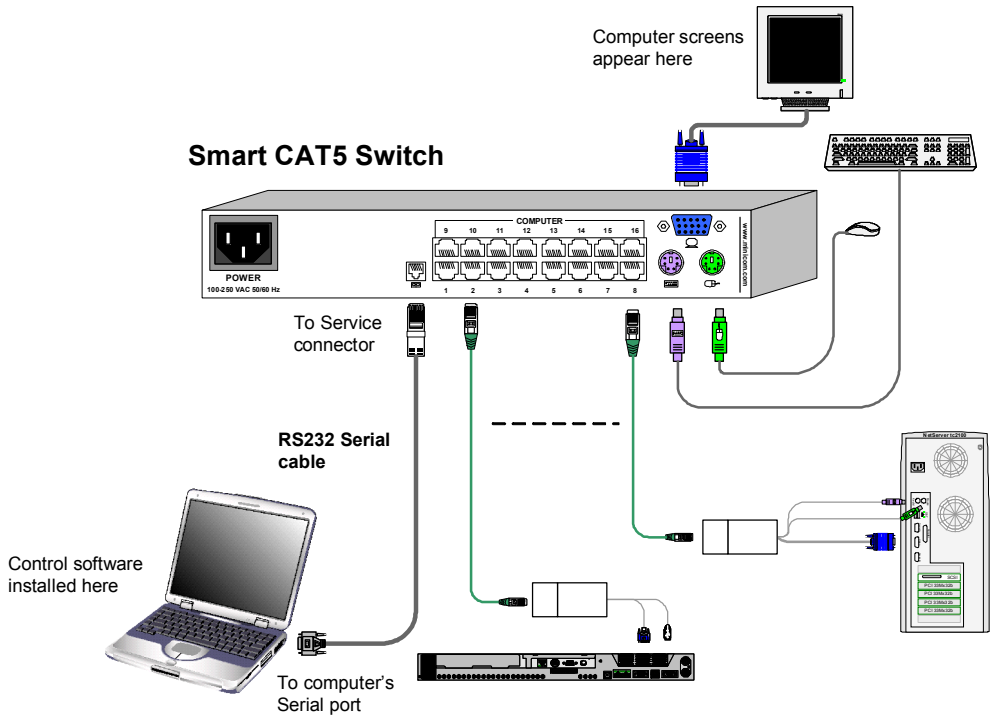

Figure 19 Connecting the RS232 Serial cable

36. Installing and running the Control software

Note! The system must be fully connected **BEFORE** running the Control software. Failure to first connect the system will lead to the software working in demo mode.

1. Download the software from www.minicom.com and install it on your computer.



Once installed, a shortcut icon appears on the Desktop

2. Double-click the icon to run the software. Or choose Start / Programs / Smart CAT5 RS232 Control / Smart CAT5 RS232 Control.

To run the software from the CD:

Choose Run Smart CAT5 switch RS232 Control Software from CD.

Selecting a Com port

During the Setup process you will be prompted to choose a Com port. Choose the Com port to which the RS232 Serial cable is connected. Failure to select the correct Com port will result in the software running in demo mode.

Once Setup is complete the Control window appears. See the figure below.

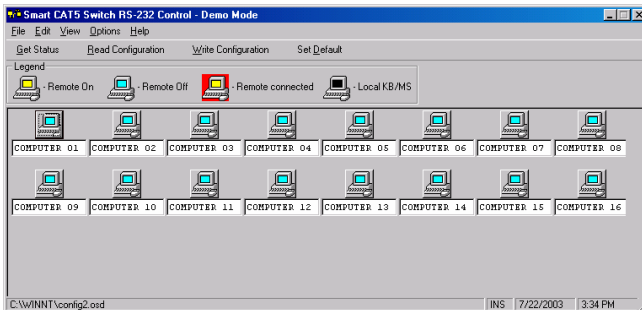





Figure 20 Control window

37. Computer icons

Icon	Meaning
	Computer is connected and switched on
	Computer is switched off or unconnected
	Computer that you are presently connected to
	Connected and switched on computer with a Local Workstation attached and presently being used locally. After remaining idle for the Timeout period, it changes to yellow .

When you first open the Control window the software automatically gets the status of the system, including the security access settings.

38. Communication Error

If a Communication Error box appears when trying to scan the system – Figure 21.

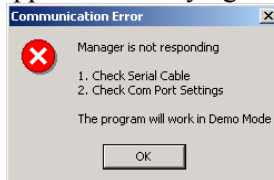

Figure 21 Communication Error

Check that:

- The RS232 Serial cable is connected to the computer's Serial port and the Smart CAT5 service port.
- The Com Port settings in **Options / Com Port** are set correctly. After changing the Com port exit and re-enter the Control software.

39. The View menu

From the **View** menu choose to display:

- All computers, or only active switched on computers.
- The Legend
- The toolbar

40. Selecting a computer

To select a computer:

Click on the computers icon. The system switches to that computer. The connected



icon appears with a red background. Control and monitor the selected computer from the keyboard and mouse connected to the Smart Switch.

41. The toolbar buttons

The toolbar buttons are explained below.

42. Get Status

If for whatever reason there is a break in communication between the Control software and the system, click **Get Status** to get the current status of the computers in system. The system automatically updates the status before every switching.

43. Read Configuration

To see the current settings of the entire system (names, scan settings etc.) click **Read Configuration**. All current settings are received. You view the computer settings from the Control window and other settings from the **Edit** menu – discussed below.

44. Write Configuration

With the Control software you can make changes to all OSD settings. You can then save these configurations in a file to use in the future by selecting **Save** or **Save As** from the **File** menu.

Note! Save or Save As will have no affect on the OSD.

To change the OSD settings you must press **Write Configuration** or choose Write Configuration from the **File** menu after making changes. The changes will then be sent to the Smart system Manager, and the OSD will reflect these changes.

45. Renaming a computer

To rename a computer:

1. Type the new name in the box below the computer icon.
2. Click **Write Configuration** to send the new name to the system.

Or click **Save** or **Save As** from the **File** menu to save the change in a file and not alter the OSD names.

46. The Edit menu

You can edit all OSD fields. Edit the following from the Edit menu.

- Logo
- Passwords
- Settings

47. Logo and Passwords

You can edit the logo that appears at the top of the OSD window. You can also edit the names and passwords for the Administrator, Supervisor and 6 Users.

1. Edit the Logo and Passwords by choosing them from the Edit menu. See figures below.

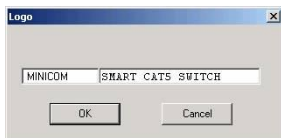

Figure 22 Logo



Figure 23 Names and passwords

2. Make the desired changes.
3. Click **OK**.

48. Settings

Choose Settings from the Edit menu. The Computers' Properties box appears. See Figure 24.

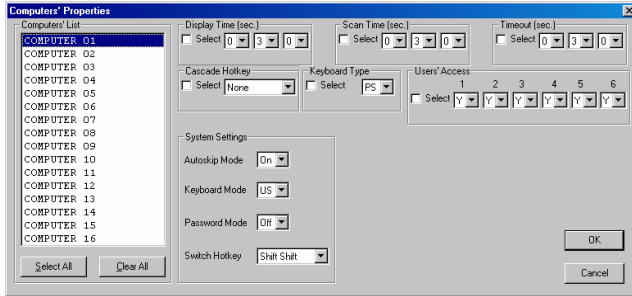

Figure 24 The Computers' Properties box

Here you can edit all the data that can be edited in the OSD. This includes:

Scan times, Timeout, Confirmation label display time, Keyboard type/mode, User access, Password mode, Autoskip mode, and Switch/System hotkey. These features are explained in the OSD section of this Appendix.

To edit a setting:

1. In the Computer List, select the desired computer or group of computers.
2. Make the desired changes.
3. Check the Select box next to the changed setting.
4. Click **OK**.

Single computer settings

To see all the settings of a single computer, right click the computer icon. The settings appear as in the figure below.

Note! There is no Select box to check.



Figure 25 The single computer Settings box

49. Loading a saved configuration

To load a saved configuration:

From the **File** menu choose **Open**.

50. Reminder!

All changes done with the Control software are only reflected in the OSD **AFTER** pressing .

51. The factory default settings

To revert to the factory default settings:

On the toolbar press .

There is no need to press .

52. Password protection

When the Smart CAT5 system is password protected, the Control software behaves in exactly the same way as the OSD. You must type in the required password to access the Control software. The access you gain depends on the security status – exactly as with the OSD.

To change the security access, close and reopen the Control software, and type in the different password.

Administrator (Status A)

The Administrator can:

- Set and modify all Passwords and security profiles
- Fully access any computer
- Use all functions

Supervisor (Status S)

The Supervisor can:

- Fully access any computer
- Scan computers.

User (Status U)

There are 6 different Users in the Smart CAT5 system. Each User has a Profile that defines the access level to different computers. There are 3 different access levels. These are:

- Y – Full access to a particular computer
- V – Viewing access only, to a particular computer (No keyboard/mouse functionality)
- N – No access to a particular computer

The Administrator defines the desired access levels of each User Profile. This is done in the Setting box. By default the User Profile settings are full access.

53. Upgrading the Smart CAT5 firmware

With the Smart CAT5 Update software program you can upgrade the firmware for the:

- OSD
- Manager
- RICCs

Smart CAT5 Update enables you to add new features and fix bugs in a quick and efficient manner. Install the Smart CAT5 Switch Update on any computer, even one not part of the Smart CAT5 system.

The Update software and the latest firmware for your system are located on our website www.minicom.com in the Support section on the Smart CAT5 Switch Upgrades page.

54. System requirements for the Smart CAT5 Update software

- Pentium 166 or higher with 16 MB RAM and 10 MB free Hard Drive space.
- Free Serial port.
- Windows 98 and later.

55. Connecting the Smart CAT5 system

To update the firmware, the Smart CAT5 system must be connected and switched on.

56. Connecting the RS232 Serial cable

To run the software, connect the RS232 Serial cable to the computer containing the software, and to the Smart CAT5 Switch. See page 24.

57. Installing the software

Download the Update software from www.minicom.com and install it on your computer.

58. Starting and configuring the Smart CAT5 Update

1. Start the Smart CAT5 Update software. The Smart CAT5 Update window appears. See Figure 26.

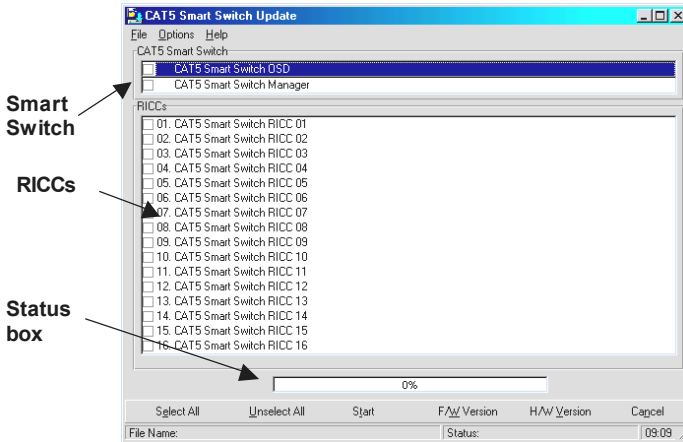

Figure 26 Smart CAT5 Switch Update window

The table below explains the functions of the buttons and boxes in the Smart CAT5 Switch Update window.

Button or Box	Function
Select All	Selects all RICC's
Unselect All	Unselects selected RICC's
Start	Starts firmware download
F/W Version	Displays the firmware version number
H/W Version	Displays the hardware version number
Cancel	Cancels selected function
10:06	System time
Status:	Displays download status
File Name:	Name of Update file

- From the Options menu choose Com Port. The Com Port box appears. See Figure 27.



Figure 27 Com Option box

- Choose an available Com Port and click OK.

Note! The RS232 Serial cable must be connected to the selected Serial port.

59. Verifying the version numbers

Before upgrading the firmware, you must first verify which firmware and hardware versions you have.

The OSD version number

To verify the OSD version number:

1. In the **Switch Unit** box, check the OSD option. See Figure 26.
2. Click **F/WVersion**. The version number appears in the **Switch** box.

The H/W Version button is grayed out, as there is no hardware relevant to the OSD.

The Smart CAT5 Manager version number

To verify the Smart CAT5 version number:

1. In the **Switch Unit** box, check the **Smart CAT5 Manager** option.
2. Click **F/WVersion**. The firmware version number appears in the **Switch Unit** box.
3. Click **H/WVersion**. The hardware version number appears in the **Switch Unit** box.

Verifying the RICC version number

Before you can check a RICC, you must uncheck the **Switch Unit** box options.

To verify the RICC version number:

1. Check one or more or all of the RICCs.
2. Click **F/WVersion**. The firmware version number appears after the RICC number.
3. Click **H/WVersion**. The hardware version number appears after the RICC number.

When “**Not responding**” appears, there is no computer connected, or it is switched off.

60. Obtaining new firmware

Download the latest firmware for your system from www.minicom.com

61. Updating the firmware

Warning!

Never switch off any computer connected to the Smart CAT5 system during the updating process.

To update the firmware:

1. In the Smart CAT5 Switch Update window, check the appropriate option in the **Switch Unit** box or the desired RICC.
2. From the **File** menu, choose **Open**. The **Open** box appears. See Figure 28.
3. Navigate to the folder that contains the firmware update file. You may only see the files that match the file selection mask.

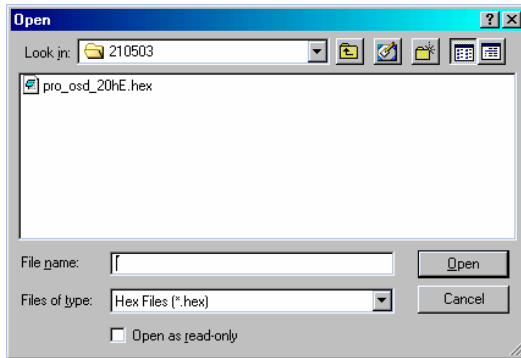

Figure 28 The Open box

4. Open the file.
5. Click **Start**. The Smart CAT5 Switch Update flashes the firmware. On completion the firmware version number appears.
6. Check that the updated version number is correct by pressing F/WVersion.

Firmware Update generates one log file per session that displays a chronological list of actions. You can read the log file in any ASCII text editor. The log file is located in the Windows directory.

62. Reset

Reset the software for the Smart CAT5 Manager or RICCs when for example the unit hangs or when the mouse fails to work properly. Resetting is done via the Serial port, and avoids the need to shut down the computer.

NOTE! The Reset function does not affect the parameters of the unit settings.

Resetting the Switch or RICC units

To reset the Switch or RICC units:

1. For the Switch, check the Smart CAT5 Switch option in the **Switch Unit** box.
For the RICCs, check one or more RICCs in the **RICC Units** box.
2. From the Options menu choose **Advanced / Reset**. The units reset. The system should now be operational.

63. RICC SUN keyboard emulation

By default the RICC SUN supports US English keyboard emulation. It also supports German and Swiss German keyboard emulation. You can download the appropriate keyboard emulation firmware from our website www.minicom.com in the Support section on the Smart CAT5 Switch Upgrades page. Upload the firmware to the RICC SUN.

Other language keyboard emulations will be posted on the Minicom Web site as they become available.

64. Troubleshooting tips

When using Firmware Update software you may sometimes get a Communication Error message.

When updating a unit and a Communication Error message appears, do the following:

1. Check that the RS232 Serial cable's RS232 connector is connected to the Switch's Communication port.
2. Check that the RS232 Serial cable's DB9F connector is connected to the DB9M Serial port on the CPU's rear panel.
3. Restart the download process.

Electricity failure

When the electricity fails while updating the Smart CAT5 firmware, do the following:

If the electricity fails during the firmware update of the Switch, a **Communication Error** message appears. Simply resume the firmware update by opening the folder that contains the firmware update file and continue from there.

If the electricity fails during the firmware update of the RICCs a **Not Responding or Upgrade Error** message appears. Restart the upgrade from the beginning.

65.USB / SUN Combo keys

The connected PS/2 keyboard does not have a special SUN keypad to perform special functions in the SUN Operating System environment. So when a RICC USB or SUN is connected to a SUN computer, the RICC emulates these SUN keys using a set of key combinations called Combo keys. See the table below.

SUN key	Combo key
Stop	Left Ctrl + Left Alt + F1
Props	Left Ctrl + Left Alt + F3
Front	Left Ctrl + Left Alt + F5
Open	Left Ctrl + Left Alt + F7
Find	Left Ctrl + Left Alt + F9
Again	Left Ctrl + Left Alt + F2
Undo	Left Ctrl + Left Alt + F4
Copy	Left Ctrl + Left Alt + F6
Paste	Left Ctrl + Left Alt + F8
Cut	Left Ctrl + Left Alt + F10
Help	Left Ctrl + Left Alt + F11
Compose	Application key or Left Ctrl + Left Alt + Keypad *
Crescent	Scroll Lock
Volume Up	Left Ctrl + Left Alt + Keypad –
Volume Down	Left Ctrl + Left Alt + Keypad +
Mute	Left Ctrl + Left Alt + F12
Sun Left ◊ key	Left Windows key
Sun Right ◊ key	Right Windows key
Alt-Graph	Right Alt or Alt Gr
Stop A	Left Ctrl + Left Alt +1

66. Technical specifications

Operating systems and Platforms	DOS, Windows, LINUX, UNIX, QNX, SGI, FreeBSD, BeOS, Novell 3.12-6, SUN
Mouse	PS/2, Wheel mouse, Intellimouse, 5-button mouse
Resolution	1600x1200@75Hz
System cable	CAT5/ 5E/ 5+/ 6/ or 7 cables. FTP or UTP 2x4x24 AWG solid wire
Transmission distance	Up to 10m/33ft

Smart CAT5 Switch	
Dimensions – 8/16 port	215.0 x 122.0 x 41.5mm / 8.46 x 4.80 x 1.63in
Weight – 8/16 port	Product – 920g / 2lbs Shipping – 1.87Kg / 4.1lbs
Power supply – 8/16 port	Internal switching 85-260 VAC 50 / 60 Hz
Connections	
System	RJ45
Serial	RJ11
Local KVM	HDD15/MiniDin6/MiniDin6
Operating / Recommended ambient temperature	0°C to 40°C/32°F to 104°F
Storage temperature	-40°C to 70°C/-40°F to 158°F
Humidity	80% non-condensing relative humidity

RICCs	PS/2	USB	SUN
Connections			
VGA	HDD15	HDD15	HDD15
Keyboard/Mouse	MiniDin6	USB	MiniDin8
System	RJ45	RJ45	RJ45
Power	From computer's Keyboard port	From USB port	From computer's Keyboard port
Product weight	107g / 0.23lb		
Shipping weight	300g/ 0.66lb		
Dimensions	91 x 41 x 24mm / 3.58 x 1.61 x 0.94in		

67. User guide feedback

Your feedback is very important to help us improve our documentation. Please email any comments to: ug.comments@minicom.com

Please include the following information: Guide name, part number and version number (as appears on the front cover).

Regional Offices

Germany

Kiel

Tel: + 49 431 668 7933

info.germany@minicom.com

France

Vincennes

Tel: + 33 1 49 57 00 00

info.france@minicom.com

Italy

Rome

Tel: + 39 06 8209 7902

info.italy@minicom.com

www.minicom.com

