

1. Introduction

Add a projector or Laptop computer or both to the Classnet Twist system using the **Classnet Twist Connection unit**.

2. Connecting the system

Connect the Classnet Twist system as set out in chapter 5 of the Classnet Twist Installation Guide.

Use CAT5 FTP cables to connect the Connection unit to the system. Connect it in the same way as a Twist student unit.

3. Connecting an overhead projector

Use a Y Screen cable to connect an overhead projector and a Connection unit to the Classnet Twist system.

The figure below illustrates the connections.

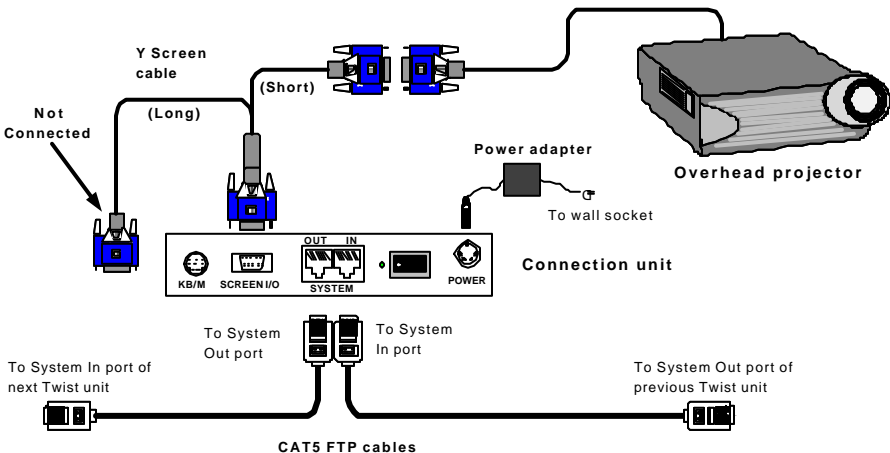

4. Operating the system with the projector

The Connection unit comes with a factory pre-set ID number of 63. This number is used when operating the system.

To transmit the teacher's screen to the projector:

On the TCU press: **From-Mastr-6-3-Enter**

To transmit a student's screen to the projector:

On the TCU press: **From-Student unit ID number-6-3-Enter**

Ending projection

To end projection press: **From**

5. Connecting a Laptop

Use the Y Screen cable to connect a Laptop and a Connection unit to the Classnet Twist system. The figure below illustrates the connections.

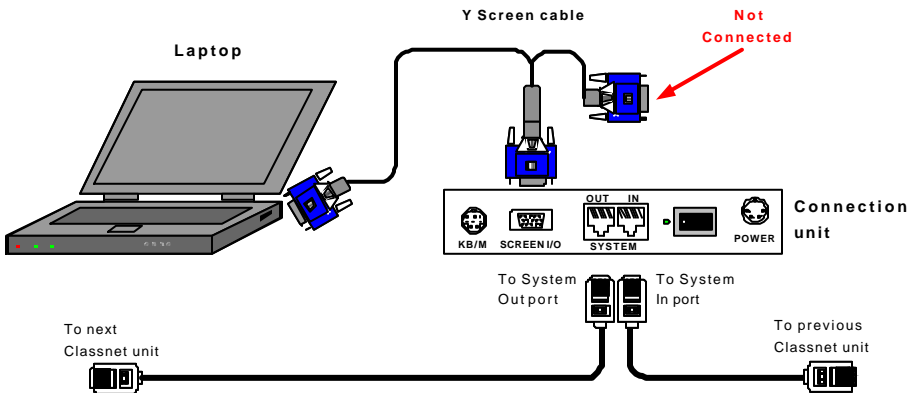

6. Operating the system with a Laptop

From the TCU transmit the Laptop screen to the whole class, a group or single student. **Important!** Press the required Laptop keys to activate the video output signal. See the Laptop's User Guide for this information.

The Connection unit comes with a factory pre-set ID number of 63. This number is used when operating the system.

To transmit the Laptop screen to the whole class:

On the TCU press: **From-6-3-All-Enter**

To transmit the Laptop screen to a student's monitor:

On the TCU press: **From-6-3-Student unit ID number-Enter**

For the Laptop to receive the screens of other monitors in the system, connect an external monitor to it. See figure above.

To transmit the teacher's screen to the Laptop:

On the TCU press: **From-Mastr-6-3-Enter**

Note! The teacher's screen appears on the external monitor.

Ending transmission

To end transmission press: **From**

7. Changing the Connection unit ID number

The Connection unit comes with a factory pre-set ID number of 63. You need to change this number if for example there are 2 Connection units in the system.

To change the ID number:

- Fully connect the Classnet Twist system including the Connection unit.
- Connect a computer, keyboard, mouse and monitor to the Connection unit using the Keyboard/Mouse cable and the Y Screen cable. See the figure below.

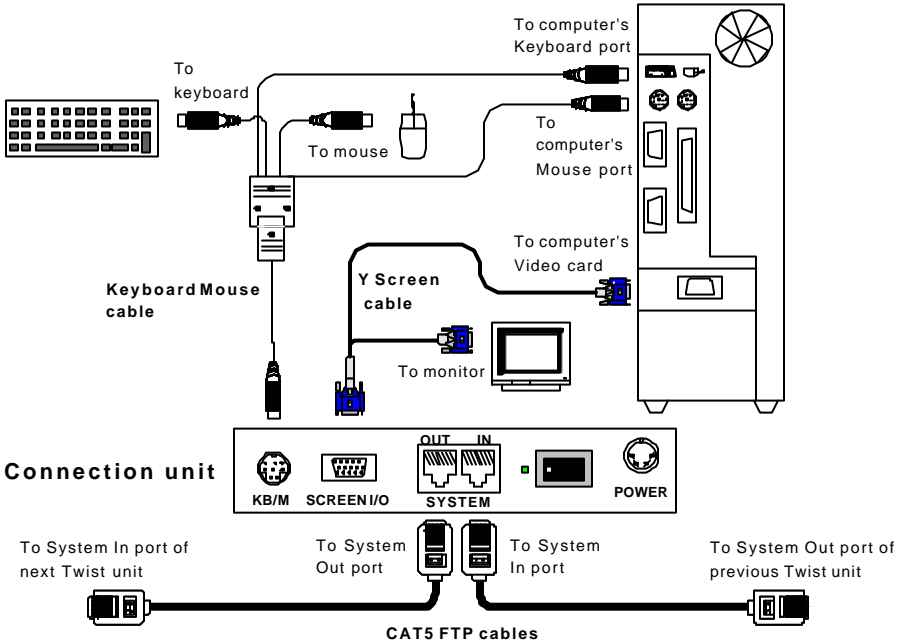

To change the ID number:

1. On the TCU press **Print-All-Enter**.
2. On the keyboard, press **Shift-Shift**. The mouse stops responding and all 3 keyboard LEDs light up.
3. Press **F1**, followed by the desired ID number. This number must have 3-digits. E.g. ID number 1 is 001.
4. Press **Esc**. The mouse now responds. The ID number is assigned.

When operating the Connection unit, replace the number 63 on pages 2 and 3 above with the new ID number.
