

Mini KVM Extender

Quick Installation Guide



International HQ

Jerusalem, Israel
Tel: + 972 2 535 9666
minicom@minicom.com

North American HQ

Linden, New Jersey
Tel: + 1 908 4862100
info.usa@minicom.com

European HQ

Dübendorf, Switzerland
Tel: + 41 1 823 8000
info.europe@minicom.com

Italy

Rome
Tel: + 39 06 8209 7902
info.italy@minicom.com

1. What is the Mini KVM Extender?

The Mini KVM Extender from Minicom extends your KVM console up to 70m/230ft. Use it to give remote access from a server room, rack or KVM switch.

2. Features

- Up to 1600 x 1200 @ 75Hz (depending on distance)
- Advanced CAT5 technology
- Pure hardware solution – real time data transfer, no software conflicts
- Plug-and-play installation – no extra protocols needed
- Multi-platform Transmitter models - PS/2 / SUN/ USB
- Field firmware upgrade for Transmitter and Receiver units
- 3 year warranty

3. Connecting the Mini KVM Extender system

The figure below illustrates the Mini KVM Extender system configuration. The universal Receiver model connects to a KVM console and is suitable for all types of Transmitter unit.

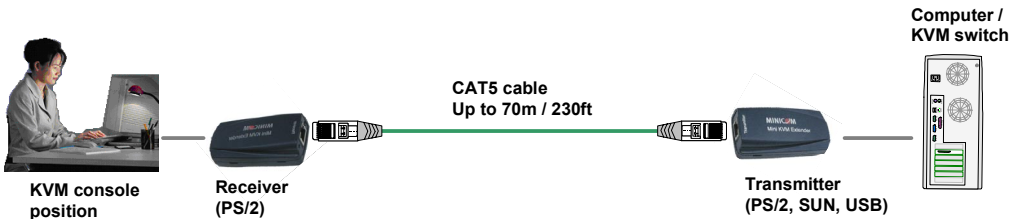

Figure 1 The Mini KVM Extender system configuration

4. Pre-installation guidelines

- Switch off the computer
- Place cables away from fluorescent lights, air conditioners, and machines that are likely to generate electrical noise

5. Connecting the Transmitter

The Transmitter comes in 3 models:

- PS/2
- SUN
- USB

Connecting a PS/2 Transmitter

Connect the PS/2 Transmitter as illustrated in Figure 2.

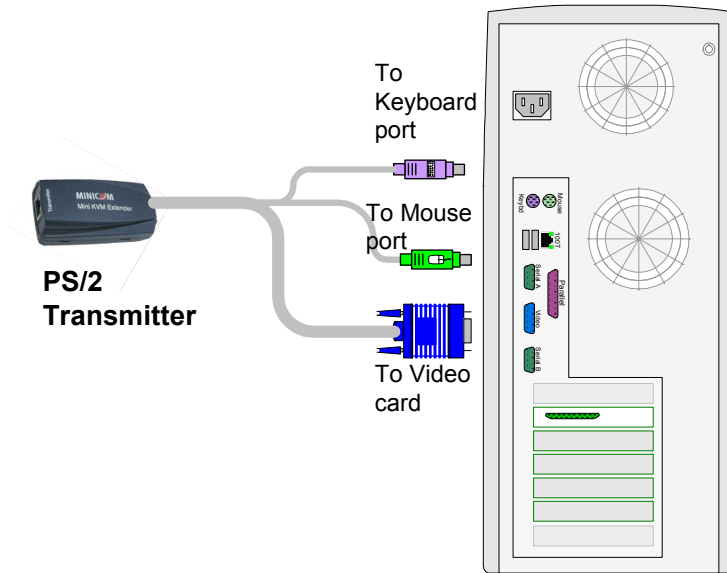

Figure 2 PS/2 Transmitter connections

Note! Although we recommend connecting the PS/2 Transmitter to a switched off computer, you can connect it to a switched on computer.

To do so you must connect it in the following order:

1. Mouse connector.
2. Keyboard connector.
3. Video connector.

Connecting a SUN Transmitter

Connect the SUN Transmitter as illustrated in Figure 3.

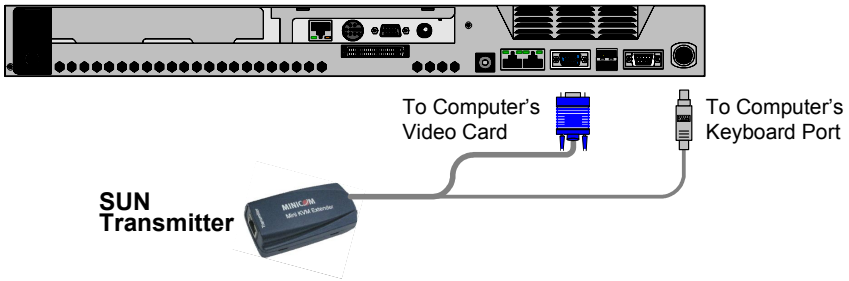

Figure 3 SUN Transmitter connections

Connecting a USB Transmitter

The USB Transmitter supports Windows 98 and later, SUN, SGI, MAC and other operating systems supporting a USB interface. Figure 4 illustrates the connections.

Connect the USB Transmitter as illustrated in Figure 4.

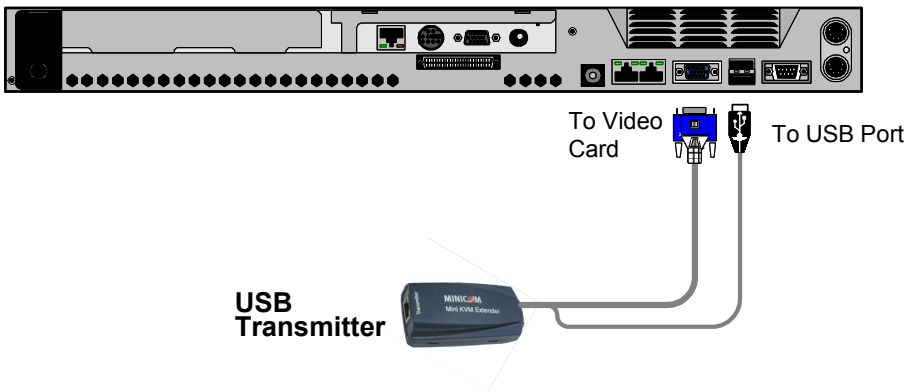

Figure 4 USB Transmitter connections

6. Connecting the CAT5/6/7 cable

A CAT5/6/7 cable connects the Transmitter to the Receiver. Connect the cable to the Transmitter's and Receiver's RJ45 ports.

7. Connecting the Receiver

Connect the Receiver to a PS/2 KVM console as illustrated below.

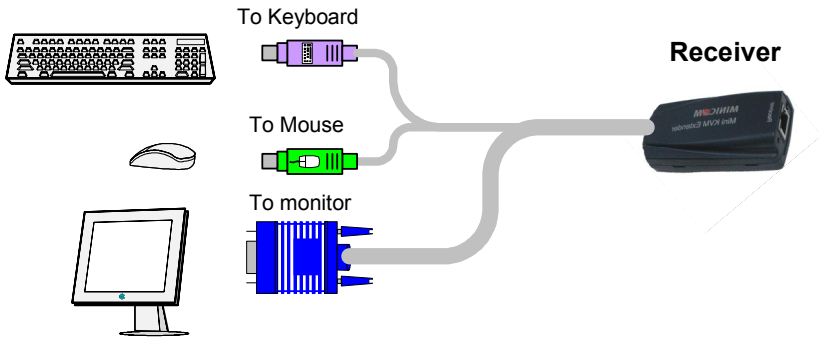

Figure 5 The Receiver connections

8. Power supply

Connect the supplied 5VDC Power adapter to the Receiver. The Transmitter receives its power from the connected computer.

9. LED indicators

Both the Transmitter and Receiver have 2 LEDs above the RJ45 port.

The green LED indicates power is on. The flashing yellow LED indicates the system is connected.

10. Switching on

Before switching on the computer connect the Transmitter.

When fully connected, the Mini KVM Extender system is ready to transmit KVM signals.

11. Picture adjuster

To get a clear projected image, use a screwdriver to turn the picture adjuster on the Receiver unit.

12. Upgrading the firmware

Download the Update software and the latest firmware from our Website www.minicom.com in the Support section. There you will also find instructions on how to perform the upgrade.

13. Configuration options

Configure the Mini KVM Extender system to:

- Work with Unix servers
- Input the monitor's DDC information
- Change the **Shift** hotkey to **Ctrl**

When you enter the configuration mode by pressing **Shift, Tab** – as set out below - all 3 LEDs illuminate. Pressing **Esc** exits the configuration mode and the LEDs return to normal.

Note! Press the keys one after the other not all together.

Working with Unix servers

Configure the system to work with Unix servers

- For HP UX, SGI and Open VMS, press **Shift, Tab, U, 1, Esc**
- For Alpha Unix, press **Shift, Tab, U, 2, Esc**
- For AIX, press **Shift, Tab, U, 3, Esc**

Display Data Channel (DDC) hotkey

Display Data Channel is a VESA standard for communication between a monitor and a video adapter

To input the monitor's DDC information into the Transmitter's memory, press:

Shift, Tab, D, Esc.

Update the DDC information if you replace the monitor. To do so, repeat the above hotkey sequence.

Changing the Shift hotkey to Ctrl

You can change the hotkey to **Ctrl**. Once you do so, replace all the instances of **Shift** appearing above to **Ctrl**.

To change to **Ctrl** press:

Shift, Tab, C, Esc.

To change back to **Shift** press:

Ctrl, Tab, S, Esc.

14. Technical specifications

System

System cable	CAT5/6/7 cable 2x4x24 AWG Solid Wire
Maximum distance	70m/230ft
Mouse support	2 or 3 or 5 button PS/2, Wheelmouse, Intellimouse Explorer
Operating systems	All major operating systems
Screen resolution	Up to 1600X1200 @ 75Hz (depending on cable length)
Warranty	3 years
Operating temp.	0°C to 40°C/32°F to 104°F
Storage temp.	-40°C to 70°C/-40°F to 158°F
Humidity	80% non condensing relative humidity

	Transmitter	Receiver
Cables & Connectors	Built-in KVM System – RJ45	VGA – HDD15F Keyboard – MiniDin6F Mouse – MiniDin6F System – RJ45
Power supply	From connected computer	External switching power adapter 5V DC 110/240
Dimensions	89 x 46 x 25.3mm / 3.5 x 1.8 x 0.9"	
Shipping weight	552g/1.21lb	

15. USB SUN Combo keys

The connected PS/2 keyboard does not have a special SUN keypad to perform special functions in the SUN Operating System environment. So when a USB or SUN Transmitter is connected to a SUN computer, the Transmitter emulates these SUN keys using a set of key combinations called Combo keys. See the table below.

SUN key	Combo key
Stop	Left Ctrl + Alt + F1
Props	Left Ctrl + Alt + F3
Front	Left Ctrl + Alt + F5
Open	Left Ctrl + Alt + F7
Find	Left Ctrl + Alt + F9
Again	Left Ctrl + Alt + F2
Undo	Left Ctrl + Alt + F4
Copy	Left Ctrl + Alt + F6
Paste	Left Ctrl + Alt + F8
Cut	Left Ctrl + Alt + F10
Help	Left Ctrl + Alt + F11
Compose	Application key or Left Ctrl + Alt + Keypad *
Crescent	Scroll Lock
Volume Up	Left Ctrl + Alt + Keypad –
Volume Down	Left Ctrl + Alt + Keypad +
Mute	Left Ctrl + Alt + F12
Sun Left ◊ key	Left Windows key
Sun Right ◊ key	Right Windows key
Alt-Graph	Right Alt or Alt Gr
Stop A	Left Ctrl + Alt + 1